

200NDINCHILL

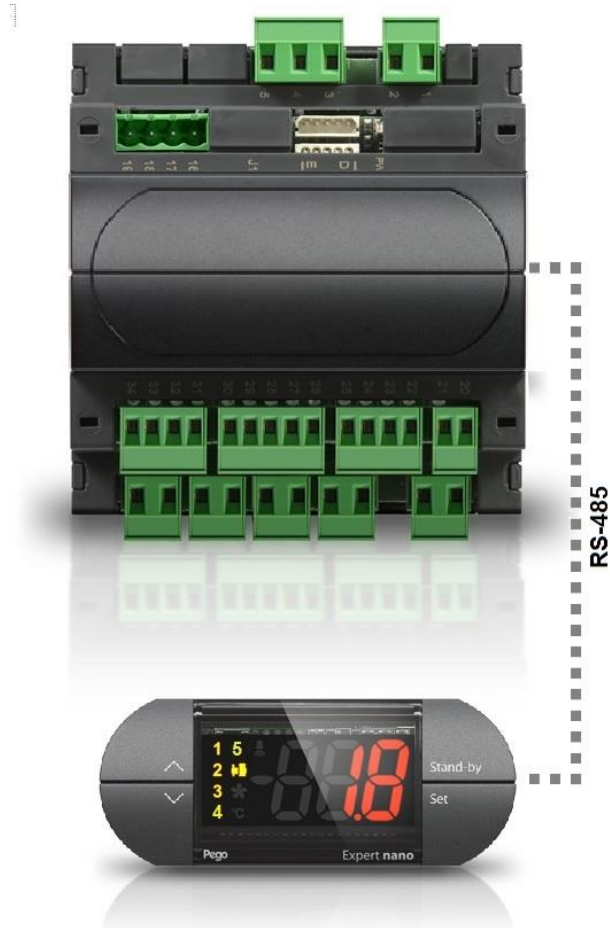

Use and maintenance manual

ENGLISH

READ AND KEEP

Rel. 4

REV. 01-24
ENG

ELECTRICAL BOARDS FOR REFRIGERATING INSTALLATIONS



TABLE OF CONTENTS

INTRODUCTION

CHAP. 1

Pag. 3	1.1	Generality
Pag. 4	1.2	Product identification codes
Pag. 4	1.3	Overall clearances
Pag. 4	1.4	Identification data

INSTALLATION

CHAP. 2

Pag. 5	2.1	Main warnings for the installer
Pag. 5	2.2	Standard equipment for assembly and use
Pag. 6	2.3	Board installation

FUNCTIONALITY

CHAP. 3

Pag. 7	3.1	Functions managed by DIN CHILL
Pag. 8	3.2	Chiller AIR - WATER
Pag. 9	3.3	Chiller WATER - WATER

TECHNICAL FEATURES

CHAP. 4

Pag. 10	4.1	Technical features
Pag. 11	4.2	Warranty conditions

DATA PROGRAMMING

CHAP. 5

Pag. 12	5.1	Control panel
Pag. 12	5.2	Front keyboard
Pag. 13	5.3	LED Display
Pag. 14	5.4	Keys combination
Pag. 15	5.5	Generality
Pag. 15	5.6	Symbols
Pag. 15	5.7	Setpoint setting and displaying
Pag. 15	5.8	First level programming
Pag. 16	5.9	List of first level programming variables
Pag. 18	5.10	Second level programming
Pag. 18	5.11	List of second level programming variables
Pag. 22	5.12	Third level programming
Pag. 22	5.13	List of third level programming variables
Pag. 25	5.14	Sequence and activation delays
Pag. 26	5.15	Evaporator management
Pag. 27	5.16	Condenser management
Pag. 30	5.17	Antifreeze adjustment
Pag. 30	5.18	Evaporator flow switch
Pag. 31	5.19	Password function
Pag. 31	5.20	Temperature table for refrigerant fluids

OPTIONS

CAP. 6

Pag. 32	6.1	Supervision/monitoring system TeleNET
---------	-----	---------------------------------------

DIAGNOSTIC

CAP. 7

Pag. 33	7.1	Diagnostic
---------	-----	------------

ATTACHMENTS

Pag. 36	A.1	EU Declaration of Conformity
Pag. 37	A.2	Electrical connections

CHAPTER 1: INTRODUCTION

GENERALITY

1.1

The **NANO DIN CHILL** system allows users to control air/water and water/water chillers in which there is more than one compressor. It guarantees uniform operation and proper distribution of operating times among individual compressors. All functions are performed in complete safety and the Control Console (REMOTE NANO DISPLAY) can be installed anywhere.

APPLICATIONS:

- Air/water and water/water chiller control.

MAIN FEATURES:

- Configurable for control air/water or water/water chillers.
- Evaporator flow switch management.
- Antifreeze protection management.
- Condensing energy saving management based on external environmental conditions.
- Configurable stand-by mode.
- 0-10V Analog output for the adjustment of speed of the condenser fans or for modulating control of the evaporator / condenser water pump.
- Display of the pressure probe measure in Bar or in °C (conversion based on the type of refrigerant gas selected).
- Rotation of compressors according to the time of operation.
- Side band regulation.
- Configurable digital inputs.
- Configurable digital outputs.
- Night / day management (energy saving).
- Clock and calendar.
- Password for keys lock.
- RS485 Serial connection (Modbus-RTU or Telenet protocol).
- Pego programming philosophy that guarantees an immediate start-up.

1.2

PRODUCT IDENTIFICATION CODES

200NDINCHILL

Air/water and water/water chiller control.

1.3

OVERALL CLEARANCES

Dimensions in mm

DISPLAY NANO CHILL

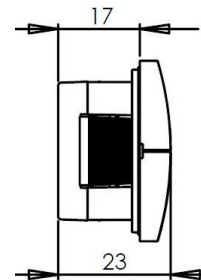
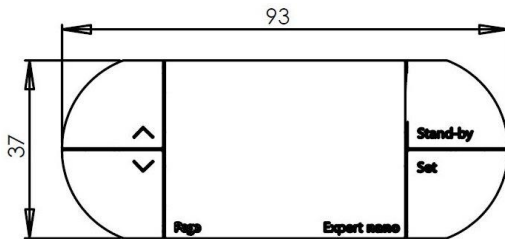

MASTER CHILL

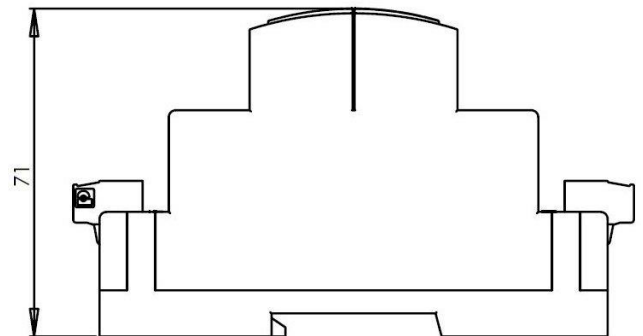
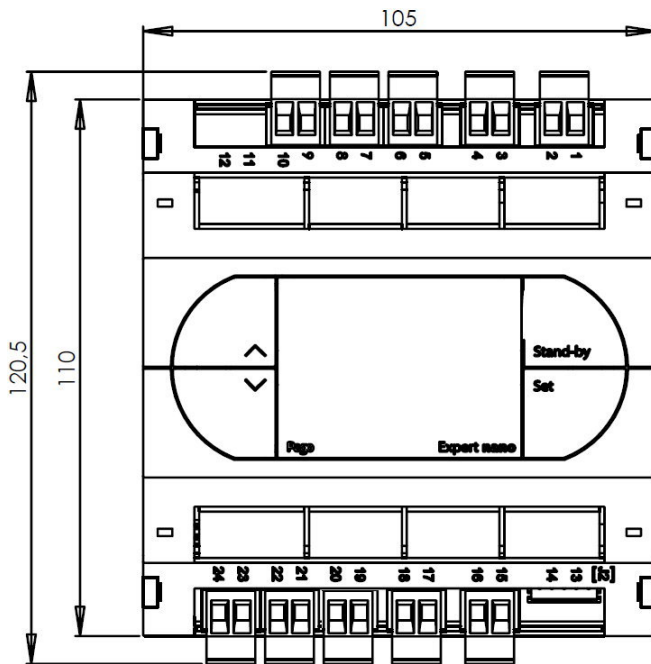

1.4

IDENTIFICATION DATA

The equipment described in this manual is provided with an identification data plate of the same placed on one side:

- Name of Manufacturer
- Equipment code
- Serial number
- Power supply voltage



CHAPTER 2: INSTALLATION

MAIN WARNINGS FOR THE INSTALLER

2.1

1. Install the equipment in places complying with the protection degree;
2. Avoid using multicore cables with conductors connected to inductive and power loads and signal conductors which probes and digital inputs;
3. Avoid housing power supply cables with signal cables (probes and digital inputs) in the same conduit
4. Reduce the lengths of the connection cables as much as possible, avoiding the wiring assuming the spiral shape, damaging for possible inductive effects on the electronics;
5. All conductors used in the wiring must be suitably proportioned to support the load to be powered;
6. Provide a main protection fuse upstream of the electronic control;
7. If required to extend the probes, use conductors with suitable section and not below 1mm². The extending or shortening of the probes may alter the factory calibration; use an external thermometer to check and calibrate.

STANDARD EQUIPMENT FOR ASSEMBLY AND USE

2.2

For assembly and use, the electronic controller **DIN NANO CHILL** is equipped with:

- N° 1 Telephone plug cable;
- N° 1 Use manual;
- N° 1 DIN NANO CHILL (200NDINCHILL);

2.3

INSTALLATION

Fig.1: Position the module on the DIN guide and close the lower hook to lock it on the same.

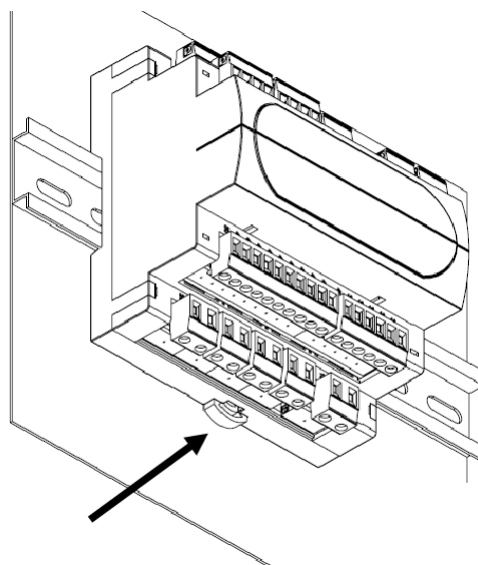

Fig.2: Fix the **NANO CHILL** console using the two screws to be inserted in the slots underneath the keys frame.

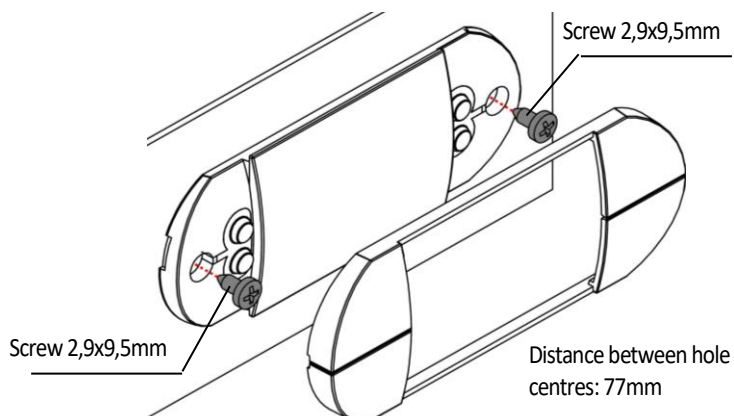

Fig.3: **NANO CHILL** console perforation template.



CHAPTER 3: FUNCTIONALITY

FUNCTIONS MANAGED BY DIN NANO CHILL

3.1

- Configurable for control air/water or water/water chillers.
- Evaporator flow switch management.
- Antifreeze protection management.
- Condensing energy saving management based on external environmental conditions.
- Energy saving with night/day function.
- Configurable stand-by mode.
- 0-10V Analogic output for the adjustment of speed of the condenser fans or for modulating control of the evaporator / condenser water pump.
- Rotation of compressors / fans according to the time of operation.
- Clock and calendar.
- RS485 Serial connection (Modbus-RTU or Telenet protocol).
- Alarm relay configurable.
- Remote Stand-by digital input.
- Digital outputs configurable as Compressor 1, Compressor 2, Compressor 3, Compressor 4, Antifreeze heater, Evaporator water pump, Condenser fan, Condenser water pump, alarm.

3.2

CHILLER AIR - WATER

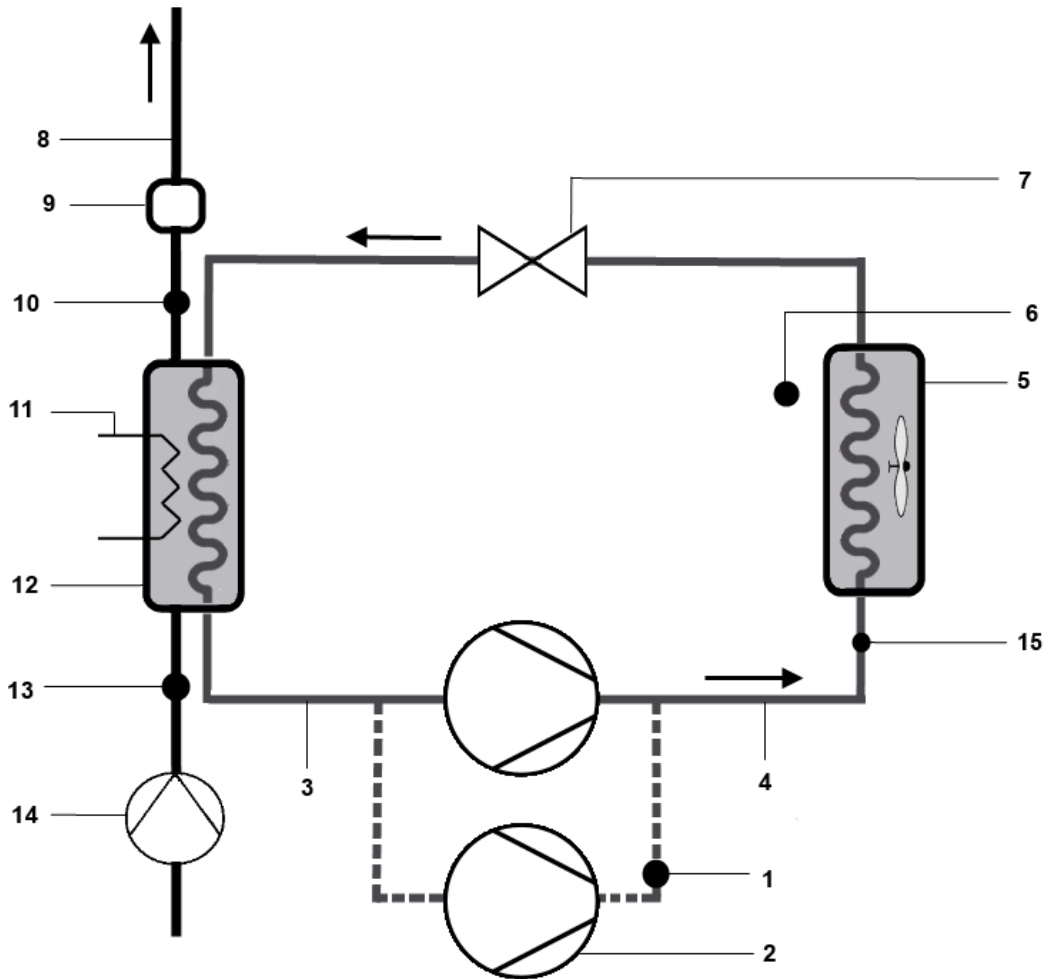

1	Compressors	9	Flow switch
2	Compressors protection	10	Antifreeze probe (evaporator delivery)
3	Low pressure	11	Heating / anti-freeze resistance evaporator
4	High pressure	12	Evaporator
5	Condenser	13	Ambient probe (Evaporator water intake)
6	External environment probe	14	Water pump
7	Expansion valve	15	Condenser pressure probe
8	Evaporator water delivery		

CHILLER WATER - WATER

3.3

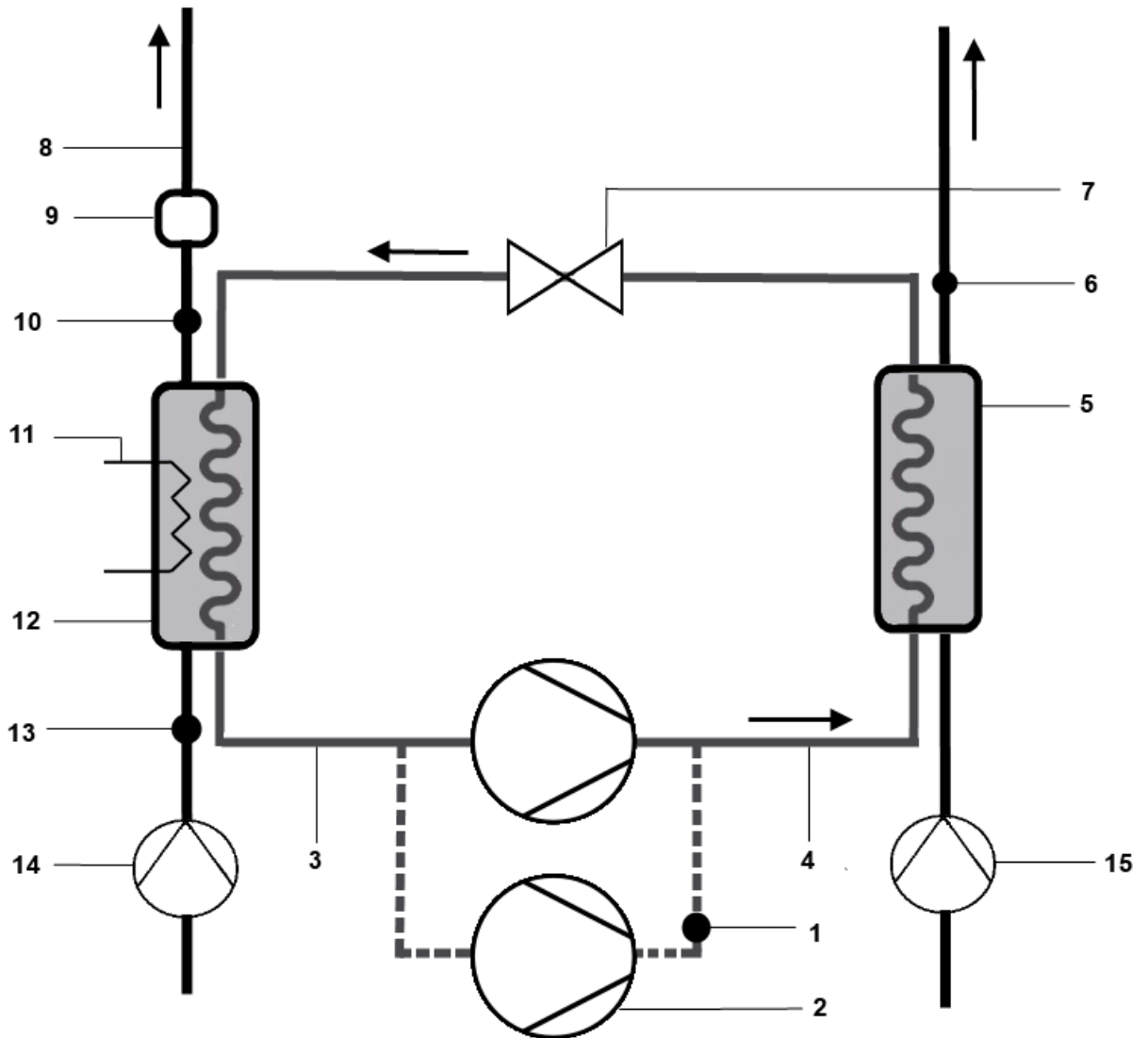

1	Compressors	9	Flow switch
2	Compressors protection	10	Antifreeze probe (evaporator delivery)
3	Low pressure	11	Heating / anti-freeze resistance evaporator
4	High pressure	12	Evaporator
5	Condenser	13	Ambient probe (Evaporator water intake)
6	Condenser water temperature probe	14	Evaporator water pump
7	Expansion valve	15	Condenser water pump
8	Evaporator water delivery		

CHAPTER 4: TECHNICAL FEATURES

4.1

TECHNICAL FEATURES

Power supply	
Model 200NDINCHILL	230V~ +10/-15% 50/60Hz
Max. absorbed power (electronic control only)	5 VA Max
Climatic Conditions	
Work temperature	-5T50°C - humidity < 90% U.R. Not condensing
Storage temperature	-10T70°C - humidity < 90% U.R. Not condensing
Unsuitable operating environments	Environments with strong vibrations or impacts; aggressive, polluted or corrosive atmospheres, exposure to direct solar radiation, explosive atmospheres or flammable gas.
General characteristics	
Display	3-Digit with sign, decimal point and 9 LED status indicators
Model 200NDINCHILL	Power clamps: extractable, screw for cables with c/section 0.2 to 2.5mm ²
Software class: A / Parameters saved on non-volatile memory (EEPROM)	
Input characteristics	
Analogue inputs	1 pressure probe : 4/20mA configurable 4 temperature probe: NTC (10KΩ 1% a 25°C)
Digital inputs	5 inputs (configurable, clean contact)
Output characteristics	
Relay 1 (DO1)	N.O. 8(6)A / 250V~
Relay 2 (DO2)	N.O. 16(3)A / 250V~
Relay 3 (DO3)	N.O. 16(6)A / 250V~
Relay 4 (DO4)	N.O. 16(6)A / 250V~
Relay 5 (DO5)	N.O. 8(3)A / 250V~
Buzzer	Present
Dimensional, insulation and mechanical characteristics	
Dimensions	Master: 105x121.5x71mm Display: 93x37x23mm
Drill hole template (display 485)	71x29mm (+0,2/-0,1mm)
Protection rating (display 485)	IP65 with front board installation
Installation (display Echo 485)	In front of board by side tabs fixing or by two front screws
Installation Master	Din rail 35mm
Casing	Plastic PC+ABS UL94 V-0 body, PC transparent front, Key panel PC or PC+ABS
Insulation type	Class II

WARRANTY CONDITIONS

4.2

The **DIN NANO CHILL** series electronic controls are covered by a 24-months warranty against all manufacturing defects as from the date indicated on the product ID code.

In case of defect the product must be appropriately packaged and sent to our production plant or to any authorized Service Center with the prior request of the Return Authorization Number.

Customers are entitled to have defective products repaired, spare parts and labour included. The costs and the risks of transport are at the total charge of the Customer. Any warranty action does not extend or renew its expiration.

The Warranty does not cover:

- Damages resulting from tampering, impact or improper installation of the product and its accessories.
- Installation, use or maintenance that does not comply with the instructions provided with the product.
- Repair work carried out by unauthorized personnel.
- Damage due to natural phenomena such as lightning, natural disasters, etc...

In all these cases the costs for repair will be charged to the customer.

The intervention service in warranty can be refused when the equipment is modified or transformed.

Under no circumstances **Pego S.r.l.** will be liable for any loss of data and information, costs of goods or substitute services, damage to property, people or animals, loss of sales or earnings, business interruption, any direct, indirect, incidental, consequential, damaging, punitive, special or consequential damages, in any way whatsoever caused, whether they are contractual, extra contractual or due to negligence or other liability arising from the use of the product or its installation.

Malfunction caused by tampering, bumps, inadequate installation automatically declines the warranty. It is compulsory to observe all the instructions in this manual and the operating conditions of the product.

Pego S.r.l. disclaims any liability for possible inaccuracies contained in this manual if due to errors in printing or transcription.

Pego S.r.l. reserves the right to make changes to its products which it deems necessary or useful without affecting its essential characteristics.

Each new release of the Pego product user manual replaces all the previous ones.

As far as not expressly indicated, is applicable the Law and in particular the art. 1512 C.C. (Italian Civil Code).

For any controversy is elected and recognized by the parties the jurisdiction of the Court of Rovigo.

CHAPTER 5: DATA PROGRAMMING

5.1

CONTROL PANEL

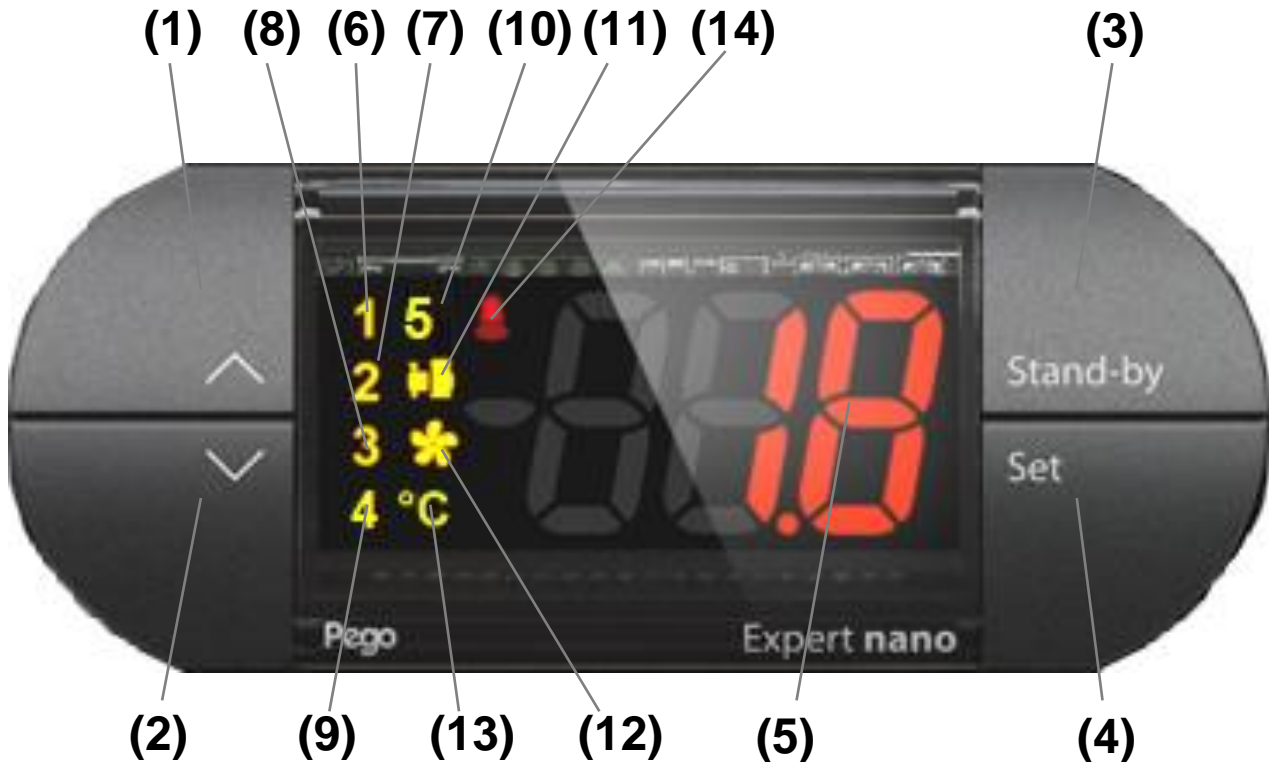

5.2

FRONT KEYBOARD

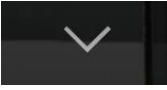
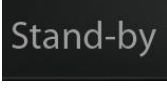
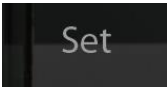
- (1)  **UP**
Increases the values / Scroll up the parameters
Reset sound alarm if any.
-
- (2)  **DOWN**
Decreases the values / Scroll down the parameters.
-
- (3)  **STAND BY**
If pressed for over 1 second alternates the Stand-By with normal mode and vice versa.
In Stand-By mode the system stops and the display signals OFF and the current view.
-
- (4)  **SET**
View the setpoint.
Allows you to set the compressors setpoint when pressed in combination with the Up or Down button.

LED DISPLAY

5.3

(5)



View values / parameters

(6)

**COMPRESSOR 1 ICON**

Led OFF = Compressor output 1 not active
 Led ON = Compressor output 1 active
 Blinking Led = Compressor 1 waiting (times t1/t2/t3/t4/t5/t6).

(7)

**COMPRESSOR 2 ICON**

Led OFF = Compressor output 2 not active
 Led ON = Compressor output 2 active
 Blinking Led = Compressor 2 waiting (times t1/t2/t3/t4/t5/t6).

(8)

**COMPRESSOR 3 ICON**

Led OFF = Compressor output 3 not active
 Led ON = Compressor output 3 active
 Blinking Led = Compressor 3 waiting (times t1/t2/t3/t4/t5/t6).

(9)

**COMPRESSOR 4 ICON**

Led OFF = Compressor output 4 not active
 Led ON = Compressor output 4 active
 Blinking Led = Compressor 4 waiting (times t1/t2/t3/t4/t5/t6).

(11)

**COMPRESSORS ICON**

LED ON = At least one compressor ON
 LED OFF = All compressors OFF

(12)

**EVAPORATOR WATER PUMP ICON**

Led ON = Evaporator pump management active (from relay or 0-10V output)
 Led OFF = Evaporator pump management not active
 Led Flashing = Evaporator pump waiting (t5 / t6 times)

(13)

**°C ICON**

Temperature display in °C

(14)

**ALARM IN PROGRESS ICON**

LED OFF = No alarm triggered
 LED ON = Alarm triggered and then cancelled
 Blinking LED = Alarm in progress

5.4

COMBINATION OF KEYS

**EXIT PROGRAMMING**

If pressed simultaneously for more than 3 seconds within any programming menu or the historical alarm allow you to exit the menu.

Exit from menu generates a confirmation beep.

**1st LEVEL PROGRAMMING**

If pressed simultaneously for more than 3 seconds allowing access to the first level programming menu (if you are not in programming). Exit from this menu takes place automatically after 30 seconds of keyboard inactivity or by pressing up arrow + down arrow (confirmation beep output).

**2nd LEVEL PROGRAMMING**

If pressed simultaneously for more than 3 seconds allowing access to the second level programming menu. At the entrance of the menu a confirmation beep is generated.

**3rd LEVEL PROGRAMMING**

If pressed simultaneously for more than 3 seconds allowing access to the third level programming menu. At the entrance of the menu a confirmation beep is generated.

**OUTPUT HOUR COUNTER**

While viewing the working time of an output within the read-only H1, H2, H3, H4, H5 parameters while pressing the SET key and pressing the STAND-BY for at least 10 seconds, the hour counter will be reset.

SWITCHING FROM Bar to °C

While viewing several variables in Bar, pressing the stand-by key and Set together switches the view from Bar to °C according to the table of the gas type selected until the keys are released.

The variables involved with this kind of view are:

CSe, Cr0, A1c, A2c, iOv

GENERALITY



5.5

For operator safety and practicality, the **NANO DIN CHILL system** envisions three programming levels; the first for configuration of the frequently amendable **SETPOINT** parameters only, the second for programming and setting of the main parameters relating to the various board functioning modes and the third for programming input/output of the board. It is not possible to directly access the second or third level from first level programming, exit current programming first.

SYMBOLS

5.6

For practicality we will use the following symbols:

- (▲) the UP key  that performs value increase functions;
- (▼) the DOWN key  that performs value decrease functions.

SETPOINT SETTING AND DISPLAYING

5.7

1. Press the SET key to display the current ambient SETPOINT.
2. Keeping the SET key pressed and pressing one of the (▲) o (▼) keys, the SETPOINT value can be amended. Release the SET key to return to displaying the regulation probe value; memorising of the made amendments will automatically happen.

LABEL	MEANING	VALUES	DEFAULT
---	Setpoint adjustment (room temperature, evaporator suction)	LSE ÷ HSE	2,0 °C

LEVEL 1 PROGRAMMING (User level)

5.8

To access Level 1 programming, press and hold the UP key (▲) and DOWN key (▼) for over 3 seconds.

When the first programming variable appears:

1. Select the variable you want to change with the key (▲) or with the key (▼). After selecting the required variable, it is possible to:
2. View its configuration by pressing the SET key.
3. Edit configuration by pressing and holding the SET key and pressing either the (▲) or (▼) key.
4. After setting the configuration values, press and hold both the (▲) key and the (▼) key for a few seconds until the cell temperature value appears and exit the menu. The system closes the menu when the keypad is not used for over 30 seconds.
5. Any changes made to the variables are saved automatically when the system closes the configuration menu.

5.9

LIST OF LEVEL 1 VARIABLES (User Level)

LABEL	MEANING	VALUES	DEFAULT
r0	SET differential of the ambient temperature	0,2 ÷ 25,0 °C	2,0 °C
t1	The minimum time that must elapse between the insertion of a compressor step and the next one. This time avoids breakaways caused by simultaneous start-ups.	2 ÷ 500 sec step 2 sec	20 sec
t2	The minimum time that must elapse between two different compressor step deactivations.	2 ÷ 500 sec step 2 sec	10 sec
t3	The minimum time that must elapse between two successive insertions of the same compressor step.	2 ÷ 500 sec step 2 sec	320 sec
t4	The minimum time that must elapse between one shutdown and the next insertion of the same compressor step.	2 ÷ 500 sec step 2 sec	2 sec
t5	Minimum time between the evaporator water pump start (cold request) and the start of the first compressor step. With cold request, the evaporator water pump is activated first and the compressor starts after t5 seconds.	2 ÷ 500 sec step 2 sec	10 sec
t6	Minimum time between turning off the last compressor step and turning off the evaporator water pump.	2 ÷ 500 sec step 2 sec	10 sec
Fty	Type of refrigerant GAS in use. The setting of this parameter is essential for correct operation	0 = R404 1 = R134 2 = R22 3 = R407A 4 = R407F 5 = R407H 6 = R410A 7 = R450A 8 = R507 9 = R513A 10=R744(CO2) 11 = R449A 12 = R290 13 = R32 14 = R448A 15 = R452A 16 = R600 17 = R600A 18 = R1270 19 = R1234ze 20 = R23 21=R717(NH3)	0
AO	Display of the 0-10V analogue output (evaporator / condenser water pump speed)	0,0 – 10,0V	Read only
ALL	View of the last alarm triggered	Alarm code	Read only

<p>A1</p>	<p>Minimum ambient temperature / minimum evaporator water inlet temperature The absolute temperature below which, once the Ald delay time is activated, the LOW temperature alarm is triggered showing EL alternating with the temperature on the display and the flashing of the alarm icon. When the alarm turns off, the "alarm presence" icon will remain lit to indicate which operation has occurred until the up button is pressed.</p>	<p>-45,0 ÷ (A2-0,1) °C</p>	<p>-45,0 C°</p>
<p>A2</p>	<p>Maximum ambient temperature / maximum evaporator water inlet temperature The absolute temperature above which, once the Ald delay time is activated, the HIGH temperature alarm is triggered showing EH alternating with the temperature on the display and the flashing of the alarm icon. When the alarm turns off, the "alarm presence" icon will remain lit to indicate which operation has occurred until the up button is pressed.</p>	<p>(A1+0,1) ÷ +99,0 °C</p>	<p>+99,0 °C</p>
<p>A1c</p>	<p>Minimum condenser temperature/pressure The absolute temperature/pressure referred to the condenser probe below which, once the Ald delay time is activated, the LOW temperature/pressure alarm is triggered showing ELc and the flashing of the alarm icon. When the alarm turns off, the "alarm presence" icon will remain lit to indicate which operation has occurred until the up button is pressed.</p>	<p>Se An4 = 1 (pressure probe): -0,6 ÷ (A2c-0,1) Bar step 0,1 Bar</p> <hr/> <p>Se An4 = 2 (temperature probe): -45,0 ÷ (A2c-0,1) °C step 0,1 °C</p>	<p>-45,0 °C</p>
<p>A2c</p>	<p>Maximum condenser temperature/pressure The absolute temperature/pressure referred to the condenser probe above which, once the Ald delay time is activated, the HIGH temperature/pressure alarm is triggered showing EHc and the flashing of the alarm icon. When the alarm turns off, the "alarm presence" icon will remain lit to indicate which operation has occurred until the up button is pressed.</p>	<p>Se An4 = 1 (pressure probe): (A1c+0,1) ÷ +90,0 Bar</p> <hr/> <p>Se An4 = 2 (temperature probe): (A1c+0,1) ÷ +99,0 °C</p>	<p>+99,0 °C</p>
<p>diS</p>	<p>Main Display</p>	<p>0 = Evaporator air intake / water inlet (room temperature) 1 = Evaporator flow temperature 2 = External environment 3 = Condensing temperature (An4 = 2) 4 = Condensing pressure (An4 = 1) 5 = Condensation pressure converted to °C (An4 = 1)</p>	<p>0</p>
<p>tdS</p>	<p>Day start time programming (ignored if dnE=0 or there is a night digital input)</p>	<p>00:00 ÷ 23:50 step 10 min</p>	<p>06:00</p>
<p>tdE</p>	<p>Day end time programming (ignored if dnE=0 or there is a night digital input)</p>	<p>00:00 ÷ 23:50 step 10 min</p>	<p>22:00</p>

5.10

LEVEL 2 PROGRAMMING (Installer level)

To access Level 2 programming, press and hold the UP key (▲), DOWN key (▼) and STAND-BY key for over 3 seconds.

When the first programming variable appears:

1. Select the variable you want to change with the key (▲) or with the key (▼). After selecting the required variable, it is possible to:
2. View its configuration by pressing the SET key.
3. Edit configuration by pressing and holding the SET key and pressing either the (▲) or (▼) key.
4. After setting the configuration values, press and hold both the (▲) key and the (▼) key for a few seconds until the pressure value appears and exit the menu.
5. Any changes made to the variables are saved automatically when you release SET button.

5.11

LIST OF LEVEL 2 VARIABLES (Installer Level)

LABEL	MEANING	VALUES	DEFAULT
SEq	Logical selection of compressors activation	0 = With rotation 1 = Without rotation	1
Man	Max. number (hours x 10) of operating hours for a compressor after which a request for maintenance will be signalled (if = 0, the request for maintenance will not be signalled)	0 ÷ 510 step 2	300
EP4 Condenser	Condenser pressure probe configuration. Pressure (bar) corresponding to 4mA.	-1,0 ÷ (EP2 - 0,1) Bar	0,0 Bar
EP2 Condenser	Condenser pressure probe configuration. Pressure (bar) corresponding to 20mA.	(EP4 + 0,1) ÷ 90,0 Bar	30,0 Bar
CA1	NTC 1 Temperature sensor calibration Water / air evaporator intake (ambient)	-10,0 ÷ +10,0	0,0 °C
CA2	NTC 2 Temperature sensor calibration Evaporator water delivery / antifreeze	-10,0 ÷ +10,0	0,0 °C
CA3	NTC 3 Temperature sensor calibration external environment (condensation control)	-10,0 ÷ +10,0	0,0 °C
CA4	NTC 4 Temperature sensor calibration Condenser temperature	-10,0 ÷ +10,0	0,0 °C
CA5	Condenser pressure probe calibration	-10,0 ÷ 10,0 Bar	0,0 Bar

ESE Evaporator	Setpoint air / water analogue output 0-10V evaporator It is the setpoint relative to the modulating output 0-10V (if AOU = 1 or AOU = 2).	-45,0 ÷ 99,0 °C	0,0 °C
Er0 Evaporator	Differential referred to the evaporator setpoint (ESE)	0,1 ÷ 30,0 °C	5,0 °C
CSE Condenser	Condensation setpoint This setpoint controls the digital output if CPd = 2 o 3. This setpoint controls the modulating output 0-10V if AOU = 3.	Se An4 = 2 (sonda di temperatura): LSc ÷ HSc °C ----- Se An4 = 1 (sonda di pressione): 0,0 ÷ 90,0 Bar	35,0 °C
Cr0 Condenser	Differential referred to the condenser setpoint (CSE)	Se An4 = 2 (sonda di temperatura): 0,1 ÷ 10,0 °C ----- Se An4 = 1 (sonda di pressione): 0,6 ÷ 5,0 Bar	4,0 °C
iOv Condenser	Condenser Fans / Water pump Inverter Offset	If: - An4=1 => 0,6 ÷ Cr0 Bar - An4=2 => 0,1 ÷ Cr0 °C	1,0 °C
iLv analog output	Analogue output: minimum value of 0-10V output with active cooling request	0 ÷ 100 %	30 %
iL2 analog output	Analogue output: minimum value of 0-10V output with cold request not active and pump / fan active.	0 ÷ 100 %	30 %
iHv analog output	Analogue output: maximum value of 0-10V output	0 ÷ 100 %	100 %
bOv analog output	Analogue output Boost: Time for which the 0-10V output of the fans is forced to 100%. This serves to overcome the inrush current at their start.	0 ÷ 240 sec	2 sec
LSE	Minimum value of ambient setpoint	-45,0 ÷ (HSE - 0,1) °C	-45,0 °C
HSE	Maximum value of ambient setpoint	(LSE + 0,1) ÷ 99,0 °C	99,0 °C
dnE	Night mode enable (energy saving) At night operation decimal point flashes.	0 = disabled 1 = enabled	0
nSC	Correction for the compressor SET during night operation (energy saving) During night operation the Compressor set is: Compressor Set = Set + nSc	-20,0 ÷ 20,0 °C	0,0
Ald	Minimum or maximum temperature alarm signalling and display delay time.	0 ÷ 240 min	120 min

AF1 Flow switch	Minimum activation time of the flow switch digital input for EFL alarm activation. Activations of shorter duration are ignored.	0 ÷ 240 sec	10 sec
AF2 Flow switch	Reactivation time with EFL flow switch alarm active. With the EFL alarm active, the pump is reactivated every AF2 minutes to verify the persistence of the flow switch alarm.	1 ÷ 240 min	10 min
AF3 Flow switch	Number of attempts to unblock flow switch alarm. If the flow is not detected after AF3 attempts (interspersed with AF2 minutes), all outputs are deactivated.	0 ÷ 20 times	6
StA Antifreeze	Antifreeze heater setpoint (Disabled if An2 = 0)	-45,0 ÷ (99,0 – r0A) °C	0,0 °C
r0A Antifreeze	Differential antifreeze heaters	0,0 ÷ 20,0 °C	2,0 °C
A1A Antifreeze	Antifreeze alarm temperature / low evaporator temperature Temperature below which, after the time A1L, the ice / low temperature alarm in the evaporator is signaled (ELe).	-45,0 ÷ StA °C (required antifreeze probe An2=1)	-5,0 °C
A1L Antifreeze	Delay time between signaling and ELe antifreeze alarm display	0 ÷ 240 min -1 = disabled (if enabled, required antifreeze probe An2=1)	-1
PES Evaporator	Evaporator water pump operation and antifreeze heaters operation during stand-by.	0 = disabled 1 = enabled. Enable evaporator water pump digital output and enable analog output (if AOU=1 or 2)	0
PCS Condenser	Condenser water pump/fan operation during stand-by.	0 = disabled 1 = enabled. Activates the condenser digital output (based on CPd) and enables the analog output (see AOU=3).	0
dAt Condenser	Energy saving condensation: room temperature difference (external condenser air temperature probe required An3 = 1 and condensation temperature control An4 = 2)	0,1 ... 99,0 °C 0 = disabled	0,0 °C
LSc Condenser	Minimum value of the condensation set point (if An4=2)	-45,0 ÷ (HSc - 0,1) °C	-45,0 °C
HSc Condenser	Maximum value of the condensation set point (if An4=2)	(LSc + 0,1) ÷ 99,0 °C	99,0 °C
BEE	Buzzer enable	0 = disabled 1 = enabled	1
Ad	Network address for connection to the TeleNET or Modbus-RTU supervision system.	0 ÷ 31 (with SEr=0) 1 ÷ 247 (with SEr=1)	1
SEr	RS-485 communication protocol	0 = TeleNET protocol 1 = Modbus-RTU protocol	0

bdr	Modbus baudrate	0 = 300 baud 1 = 600 baud 2 = 1200 baud 3 = 2400 baud	4 = 4800 baud 5 = 9600 baud 6 = 14400 baud 7 = 19200 baud 8 = 38400 baud	5
Prt	Modbus parity check	0 = no parity bit 1 = even parity bit 2 = odd parity bit		0
P1	Password: type of protection (active when PA is not 0)	0 = shows only the set point and permits deactivation of the alarms. 1 = disables access to level 1, 2 and 3 programming (access permitted to all other functions) 2 = disables access to level 2 and 3 programming (access permitted to all other functions).		2
PA	Password (see P1 for the type of protection)	0 ÷ 999 0 = function disabled		0
Yr	Year setting (Date)	00 ÷ 99		19
Mo	Month setting (Date)	01 ÷ 12		01
dY	Day setting (Date)	01 ÷ 31		01
Hr	Hour setting (Time)	00 ÷ 59		12
min	Minute setting (Time)	00 ÷ 23		00
dEF	Reserved parameter	Press all the keys for 10 seconds to restore the default parameters.		Read only
reL	Software release	---		Read only

5.12

LEVEL 3 PROGRAMMING (Installer level)

To access Level 3 programming, press and hold the UP key (▲) and STAND-BY key for over 3 seconds.

When the first programming variable appears:

1. Select the variable you want to change with the key (▲) or with the key (▼). After selecting the required variable, it is possible to:
2. View its configuration by pressing the SET key.
3. Edit configuration by pressing and holding the SET key and pressing either the (▲) or (▼) key.
4. After setting the configuration values, press and hold both the (▲) key and the (▼) key for a few seconds until the pressure value appears and exit the menu.
5. Any changes made to the variables are saved automatically when you release SET key.

5.13

LIST OF LEVEL 3 VARIABLES (Installer Level)

VAR	MEANING	VALUES	DEF.
DO1	Digital output 1 Configuration	8 = Alarm relay (N.O.) 7 = condenser fans / condenser water pump (N.O.) 6 = evaporator water pump (N.O.) 5 = Heating / anti-freeze resistance (N.O.) 4 = Compressor 4 (N.O.) 3 = Compressor 3 (N.O.) 2 = Compressor 2 (N.O.) 1 = Compressor 1 (N.O.) 0 = Disabled -1 = Compressor 1 (N.C.) -2 = Compressor 2 (N.C.) -3 = Compressor 3 (N.C.) -4 = Compressor 4 (N.C.) -5 = Defrost / antifreeze resistance (N.C.) -6 = evaporator water pump (N.C.) -7 = condenser fans / condenser water pump (N.C.) -8 = Alarm relay (N.C.)	1
DO2	Digital output 2 Configuration	- Same value legend as C1 -	5
DO3	Digital output 3 Configuration	- Same value legend as C1 -	6
DO4	Digital output 4 Configuration	- Same value legend as C1 -	7
DO5	Digital output 5 Configuration	- Same value legend as C1 -	8

DI1	Digital input 1 Configuration	<p>13 = generic alarm ('Err' only display, N.O.) 12 = night input (energy saving, N.O.) 11 = high pressure switch (N.O.) 10 = low pressure switch (N.O.) 9 = antifreeze alarm (N.O.) 8 = remote stand-by (N.O.) 7 = condensation pump / fan protection (N.O.) 6 = evaporator water pump protection (N.O.) 5 = evaporator flow switch (N.O.) 4 = compressor 4 protection (N.O.) 3 = compressor 3 protection (N.O.) 2 = compressor 2 protection (N.O.) 1 = compressor 1 protection (N.O.) 0 = disabled</p> <p>-1 = compressor 1 protection (N.C.) -2 = compressor 2 protection (N.C.) -3 = compressor 3 protection (N.C.) -4 = compressor 4 protection (N.C.) -5 = evaporator flow switch (N.C.) -6 = evaporator water pump protection (N.C.) -7 = pump / condensing fan protection (N.C.) -8 = remote stand-by (N.C.) -9 = antifreeze alarm (N.C.) -10 = low pressure switch (N.C.) -11 = high pressure switch (N.C.) -12 = night input (energy saving, N.C.) -13 = generic alarm ('Err' only display, N.C.)</p>	1
DI2	Digital input 2 Configuration	- Same value legend as DI1 -	5
DI3	Digital input 3 Configuration	- Same value legend as DI1 -	7
DI4	Digital input 4 Configuration (clamp 34-32) configuration ignored if An3 is not 0	- Same value legend as DI1 -	10
DI5	Digital input 5 Configuration (clamp 34-33) configuration ignored if An4 = 2	- Same value legend as DI1 -	11
An2	Presence of antifreeze probe (NTC)	0 = probe absent 1 = NTC temperature probe (clamps 34-31)	0
An3	Presence of external environment probe (NTC)	0 = probe absent 1 = NTC temperature probe (clamps 34-32)	0
An4	Condenser probe configuration	0 = probe absent 1 = 4-20mA pressure probe (clamps 30-28) 2 = NTC temperature probe (clamps 34-33)	0
EPd Evaporator	Evaporator water pump configuration	1 = activated if cold call active 2 = continuous operation	1
CPd Condenser	Condensing pump / fan configuration	1 = activated if cold call active 2 = regulation on condenser probe (parameters CSe and Cr0), with active cold call 3 = regulation on condenser probe (parameters CSe and Cr0), continuous operation 4 = continuous operation	1

AOU analog output	Analog output configuration 0-10V	0 = disabled 1 = 0-10V evaporator modulating pump, regulation on evaporator / antifreeze flow probe (An2> 0) 2 = 0-10V evaporator modulating pump, regulation on room probe / evaporator suction 3 = 0-10V condenser pump / fan	0
H1	Digital output 1 hour counter (resettable)*	0 ÷ 999 tens of hours	Read only
H2	Digital output 2 hour counter (resettable)*	0 ÷ 999 tens of hours	Read only
H3	Digital output 3 hour counter (resettable)*	0 ÷ 999 tens of hours	Read only
H4	Digital output 4 hour counter (resettable)*	0 ÷ 999 tens of hours	Read only
H5	Digital output 5 hour counter (resettable)*	0 ÷ 999 tens of hours	Read only

(* Digital output operation times are reset by displaying the desired hour counter (Hr1, Hr2, ecc.) and pressing SET and STAND-BY simultaneously for at least 10 seconds. When this time has elapsed, a beep confirms that the task has been completed.

The activation logic of the compressors is selected by parameter Seq.

With **SEq=1**, the activation of compressors always follows the 1, 2, 3, 4 sequence and the 4, 3, 2, 1 disabling one complying with the **t1**, **t2**, **t3**, **t4** times. If an output is not available because it is alarm, it will be temporarily excluded from the sequence.

With **SEq=0** the activation/deactivation of the compressors is operation time-based, and in particular:

- The compressor that has the least number of operating hours in times **t1**, **t2**, **t3** and **t4**, and that is available at that time (therefore not in alarm).
- The compressor that has the largest number of operating hours in times **t1**, **t2**, **t3**, **t4** is deactivated.

Delays on the activations of the outputs

"**t1**" determines the minimum time that must elapse between the insertion of a step and the next one. This parameter avoids breakaways caused by simultaneous start-ups.

"**t2**" determines the minimum time that must elapse between the deactivation of two different steps.

"**t3**" determines the minimum time that must elapse between two subsequent insertions of the same step. This parameter allows you to limit the number of start-ups per hour if the controlled motors require this.

"**t4**" determines the minimum time that must elapse between one shutdown and the next insertion of the same compressor step.

"**t5**" determines the minimum time between the switching on of the evaporator water pump (which starts at the time of the cold request) and the start of the first compressor step. This parameter reduces the risk of freezing of water inside the evaporator.

"**t6**" determines the minimum time between turning off the last compressor step and turning off the evaporator water pump. This parameter reduces the risk of freezing of water inside the evaporator.

On the display the icons relative to compressors (see par 5.3) will flash when its output is pending ON or OFF due to these times.

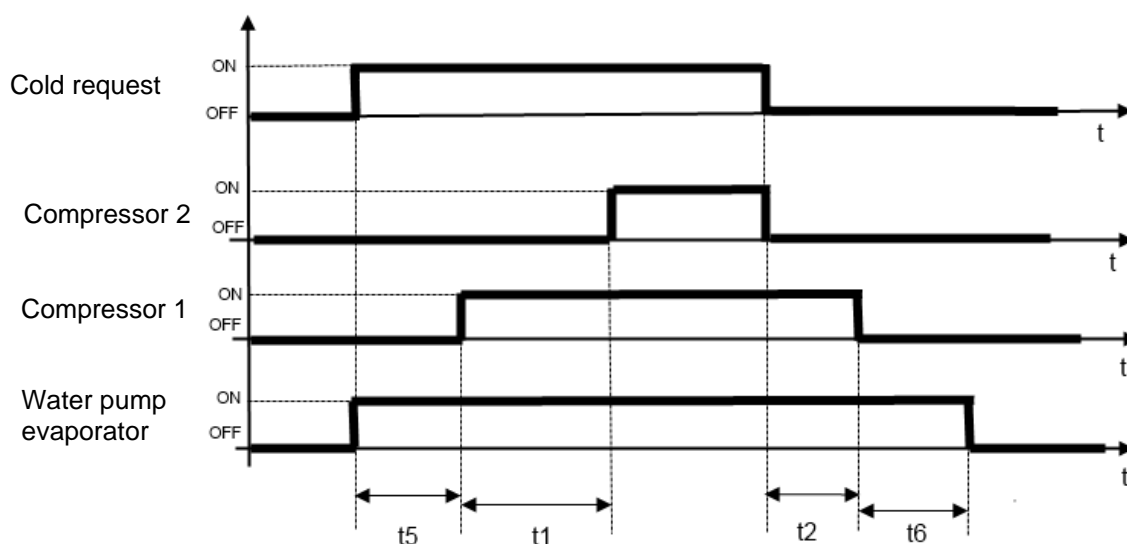

5.15

EVAPORATOR MANAGEMENT

- EVAPORATOR PUMP DIGITAL OUTPUT

Enabling conditions

The evaporator pump digital output is enabled if there is at least one digital output configured as an evaporator water pump (parameter DO1 / DO2 / DO3 / DO4 / DO5 = 4).

Operation:

The evaporator water pump, based on the **EPd** parameter, can be:

- active only with the compressor call (**EPd = 1**);
- always active (**EPd = 2**).

If the control is in STAND-BY, the evaporator is active if the parameter **PES = 1** and **EPd = 2**.

Warning! In the air / water machines with active antifreeze heater, the water pump must be activated in order to avoid the risk of fire. For this reason, when the antifreeze heaters are activated, the evaporator water pump will also be activated.

- ANALOGUE OUTPUT MODULATING EVAPORATOR PUMP

Enabling conditions

The operation of the analog output of the evaporator pump modulation depends on different parameters:

- if parameter **AOU = 1**, regulation according to the antifreeze temperature probe (set **An2 = 1**)
- if parameter **AOU = 2**, regulation on room probe / evaporator suction (always present)
- if **EPd = 1** the analogue output regulation is activated only with active cold call
- if **EPd = 2**, the analogue output adjustment is always active
- during STAND-BY the evaporator water pump modulation is active if the parameter **PES = 1** and **EPd = 2**.

Operation

The speed modulation of the evaporator pump is designed to maintain the temperature of the water leaving the evaporator around the set point ESE; if the evaporator outlet temperature drops, the controller increases the speed of the water pump by counteracting the temperature drop and trying to avoid a possible anti-freeze condition.

The water pump operates at minimum speed until the ESE setpoint is reached. Within the differential Er0, the regulation is proportional according to the evaporator water outlet temperature: the lower the temperature and the greater the rotation speed of the pump.

At any time, the request to turn on the temperature control compressors, the pump reaches the maximum speed for the time set by parameter (**BOv**).

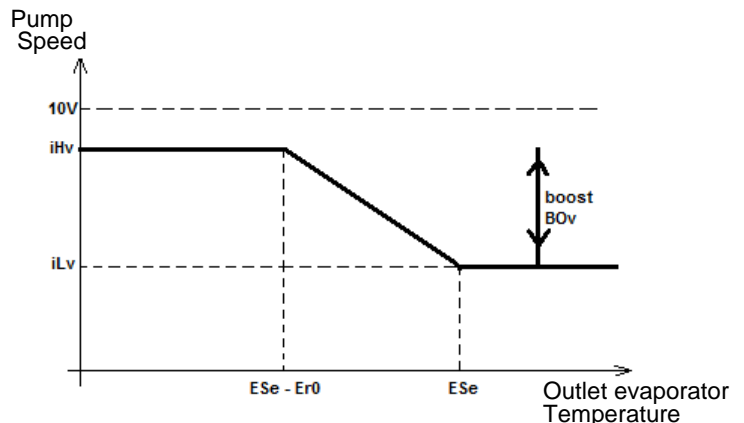

- WATER PUMP / FAN CONDENSER DIGITAL OUTPUT

Enabling conditions

The water pump/fan condenser digital output is enabled if there is at least one digital output configured as a condenser water pump / fan (parameter DO1 / DO2 / DO3 / DO4 / DO5 = 5) and if the condenser analogue output is not enabled (AOU parameter different from 3).

Operation

The condenser water pump / fan, according to parameter **CPd**, can be:

- if **CPd = 1**, enabled and activated with the compressor call;
- if **CPd = 2**, enabled with the compressor call, but activation is based on the value of the condenser probe and its CSe setpoint. In particular:
 - If **An4 = 1** it is necessary to connect a 4-20mA pressure probe (terminal 30-28); the condensing setpoint parameters (CSe) and the corresponding differential (Cr0) are set in BAR.
 - If **An4 = 2** it is necessary to connect to an NTC temperature probe (terminal 34-33); the condensing setpoint parameters (CSe) and the corresponding differential (Cr0) are set in ° C.
- if **CPd = 3**, always enabled, but the activation is based on the value of the capacitor probe and its CSe setpoint. In particular:
 - If **An4 = 1** it is necessary to connect a 4-20mA pressure probe (terminal 30-28); the condensing setpoint parameters (CSe) and the corresponding differential (Cr0) are set in BAR.
 - If **An4 = 2** it is necessary to connect to an NTC temperature probe (terminal 34-33); the condensing setpoint parameters (CSe) and the corresponding differential (Cr0) are set in ° C.
- if **CPd = 4**, always enabled and active.

Operation with Cpd=2 or 3

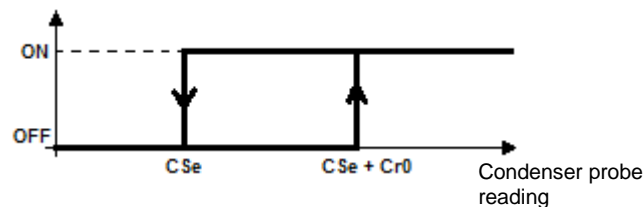

- WATER PUMP / FAN CONDENSER ANALOG OUTPUT

Enabling conditions

Set parameter **AOU = 3** to enable the condenser modulating pump / fan management.

Operation depends on several parameters:

- if **CPd = 1**: condenser water pump / fan active at maximum iHv speed when at least one compressor is active (regardless of the value of **An4**).
- if **CPd = 2**: management of condenser water pump / fan enabled with compressor active, but activation is based on the value of the condenser probe and its CSe setpoint. In particular:
 - If **An4 = 1** it is necessary to connect a 4-20mA pressure probe (terminal 30-28); the condensing setpoint parameters (CSe) and the corresponding differential (Cr0) are set in BAR.
 - If **An4 = 2** it is necessary to connect an NTC temperature probe (terminal 34-33); the condensing setpoint parameters (CSe) and the corresponding differential (Cr0) are set in °C.
- if **CPd = 3**: condenser water pump / fan management always enabled, but activation is based on the value of the condenser probe and relative CSe setpoint. In particular:
 - If **An4 = 1** it is necessary to connect a 4-20mA pressure probe (terminal 30-28); the condensing setpoint parameters (CSe) and the corresponding differential (Cr0) are set in BAR.
 - If **An4 = 2** it is necessary to connect an NTC temperature probe (terminal 34-33); the condensing setpoint parameters (CSe) and the corresponding differential (Cr0) are set in °C.
- if **CPd = 4**: water pump / condenser fan always active at maximum iHv speed.

Operation

If the condenser modulating pump / fan is enabled, the corresponding digital output becomes modulating pump / fan digital enable. If the modulating pump / fan function is not enabled, the fan / pump output follows the operation indicated in CPd.

The regulation follows the operation of the graph n.1 when the condensation pressure / temperature increases and the graph n.2 when decreases. For simplicity, the value of the pressure / temperature probe is defined as the control probe, Setpoint = CSe and differential = Cr0.

Output pressure INCREASE (Graph n.1):

The analogue output of the adjuster will be 0V for output pressure probe less or equal to point (B) representing the "SET point + iOv offset" value. If the output pressure probe value is higher than point (B), you will have the analogue output at 10V for the maximum BOv time. BOv is the Fans Boost times for which the adjuster output is increased by 100% in order to help the start-up of the fans. Between points (B) and (C), the analogue output will have a value proportional to the value of the output pressure probe starting from the minimum value of the parameter (iMv) up to the maximum value of 10V. With output pressure probe values equal or higher than point (C), you will have a 10V analogue output. Digital output no.1 represents "the condenser fans inverter activation" and is ON for pressure values higher than or equal to the set point and OFF for lower values.

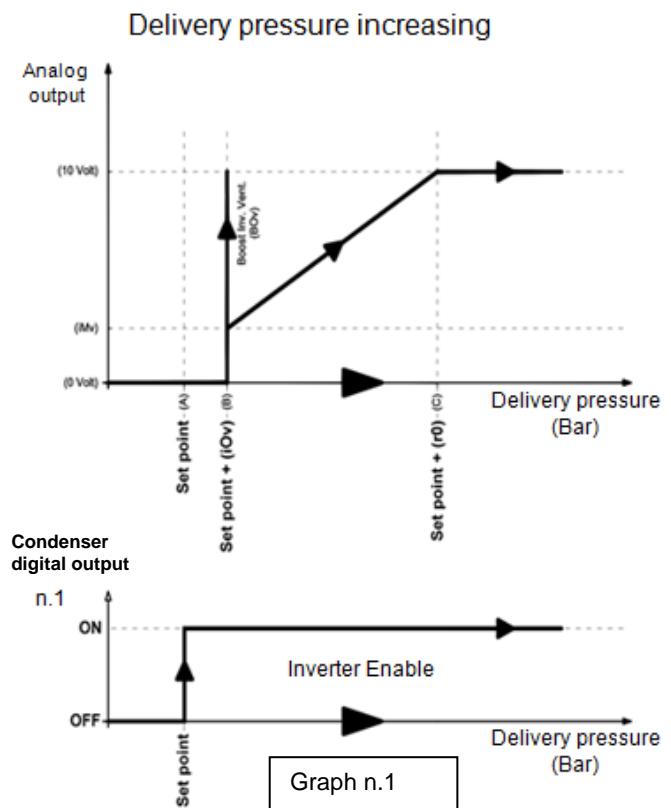

Output pressure DECREASING (Graph. n.2):

With output pressure probe values equal or higher than point (D), the analogue output will be equal to the maximum value (iHv).

Between points (D) and (E), the analogue output will have a value proportional to the value of the output pressure probe starting from the maximum value (iHv) up to the minimum value of the (iLv) parameter.

With values of the output pressure probe lower than point (E) and higher than point (F), you will have an analogue output equal to the minimum value of the (iLv) parameter.

The analogue output of the adjuster will be 0V for output pressure probe less or equal to point (F) representing the "SET point" value.

Digital output no.1 represents "the condenser fans inverter activation" and is ON for pressure values higher than or equal to the set point and OFF for lower values.

Delivery pressure decreasing

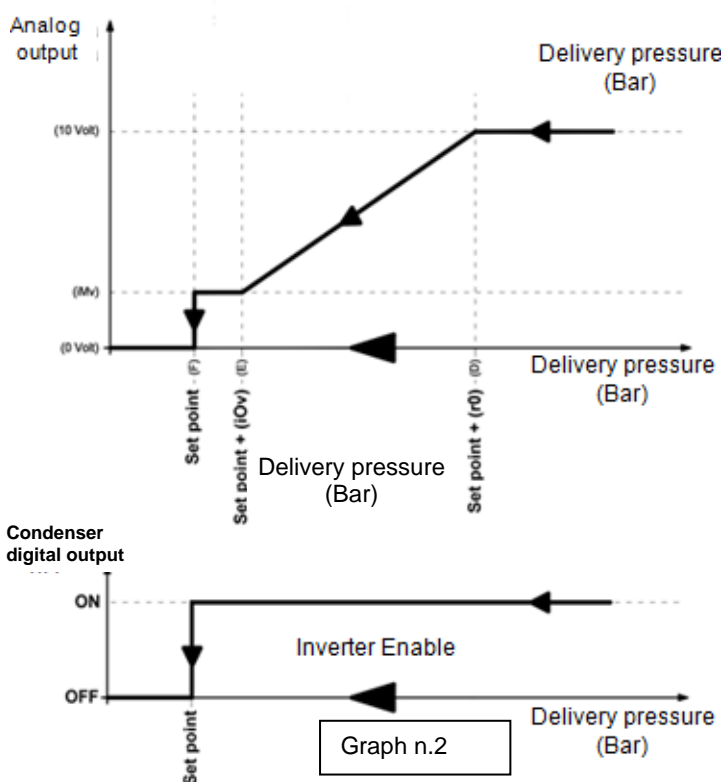

- CONDENSATION ENERGY SAVING

Enabling conditions

To activate the condensation energy saving management according to seasonal conditions it is necessary to:

- set **dAt > 0** (external temperature differential);
- set **An3 = 1** (enable external NTC probe, terminal 34-32);
- set **An4 = 2** (enable condensation temperature NTC probe, terminal 34-33), necessary for the correct comparison with the outside temperature;
- set **CPd = 2** (management only with cold call) or **CPd = 3** (continuous management) to have the regulation based on the adaptive setpoint.

Operation

In this mode the control modifies the Set-point according to the external temperature (CSe setpoint is ignored). When the external temperature drops, so does the set-point. This ensures that a fixed differential is maintained between the condensing temperature and the external temperature, therefore if the external temperature drops, so does the reference for the condensing temperature and as a result the compressor efficiency improves. In this mode the set-point is therefore set automatically and the parameters (LSc) and (HSc) set become the adjustment limits.

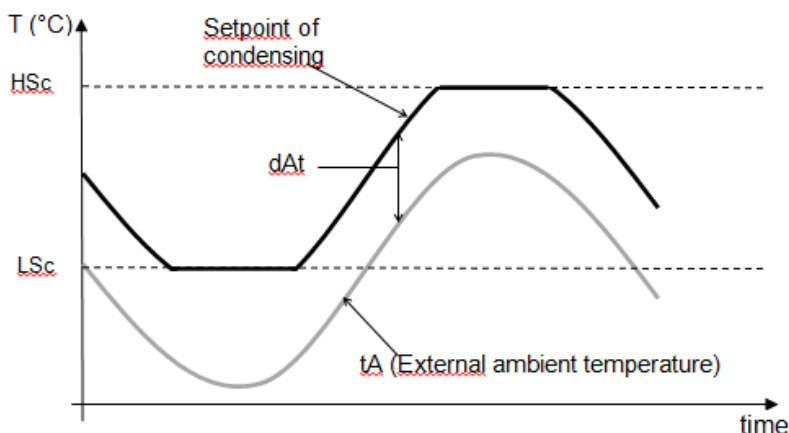

5.17

ANTIFREEZE ADJUSTMENT

The antifreeze regulation is designed to prevent the formation of ice in the evaporator circuit by activating a special heating resistor.

Enabling conditions

To enable the management of the antifreeze heater:

- set the parameter **An2 = 1** (antifreeze probe present and positioned in the evaporator outlet);
- set at least one digital output as antifreeze heater (parameter DO1 / DO2 / DO3 / DO4 / DO5 = 3)

To activate the ELE antifreeze alarm, set parameter **A1L > 0** (alarm activation delay) and set parameter **A1A** to the desired alarm temperature.

Operation

The antifreeze heater is activated if the temperature measured by the water probe supply is less than the **StA** parameter, while it's deactivated when such temperature rises above **StA + r0A**. The antifreeze alarm activates if, however the activation of the resistance, the temperature measured by the supply water probe is less than the alarm threshold **A1A**.

In this case the compressors are switched off to stop the refrigeration process, while the evaporator water pump remains active to avoid risks of freezing of the water inside the circuit. The antifreeze regulation is always active when the thermoregulation is active (if the probe is present and the resistors are present). If the chiller is in stand-by, it's possible to control the water in the circuit through the **PES** and **EPd** parameters.

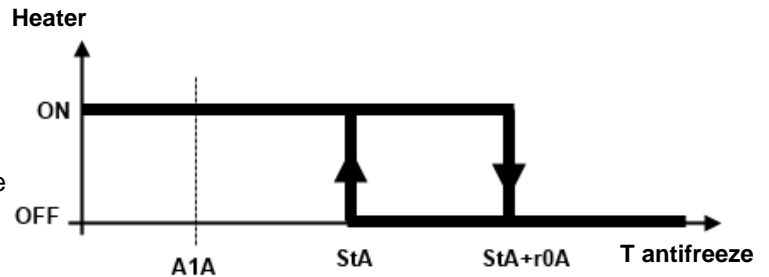

5.18

EVAPORATOR FLOW SWITCH

Enabling conditions

Set at least one digital input as a flow switch input (DI1 / DI2 / DI3 / DI4 / DI5 = +/- 3).

Operation

If the digital flow switch input remains active (ie there is no flow in the system) for a time longer than AF1 the EFL flow switch alarm is signaled.

After AF2 minutes the system is reactivated (considering all the delays t1, t2, ... t6): if the flow is still absent for AF1 seconds (flow switch input active) the system is stopped again for AF2 minutes; otherwise the EFL alarm is reset and normal operation is restored.

This cycle is repeated AF3 times, then the system is permanently stopped and the only way to reset the EFL alarm is to manually put the instrument in stand-by.

Note. The flow switch alarm is related to pump operation. If the pump is always active (parameter Epd = 2) the alarm is always possible; if the pump is active only with an active cold call (parameter Epd = 1) the flow switch alarm is only possible with the compressor on. If the pump is not associated with any physical output (DO1 / 2/3/4/5 other than +/- 4) the flow switch alarm still follows the operation set in the Epd parameter (always possible if Epd = 2 or only with compressor active if Epd = 1).

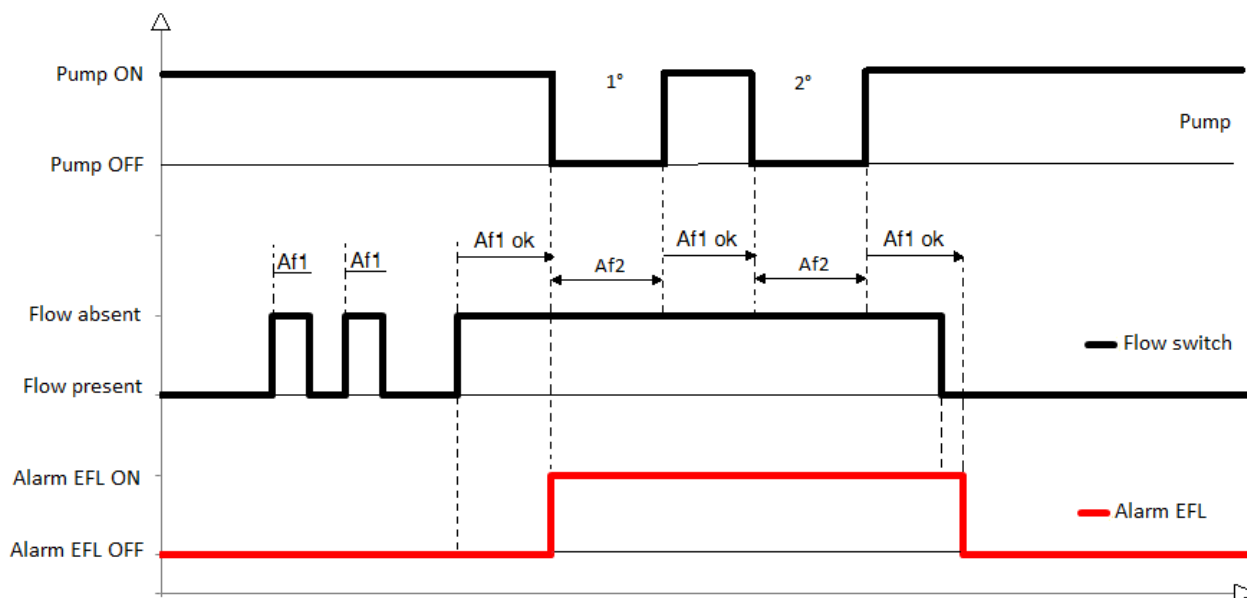

PASSWORD FUNCTION

5.19

The password function is enabled by setting a value other than 0 in the PA parameter. See parameter P1 for the various levels of protection.

Protection is enabled automatically when the keypad is not used for 30 seconds.

The digits 000 appear on the display. Use the up/down arrow keys to edit the number and press the SET key to confirm. The 000 password window disappears if the keypad is not used for 30 seconds. If you forget the password, use the universal number 100.

TEMPERATURE TABLE FOR REFRIGERANT FLUIDS

5.20

The following table shows the limits for the converted temperature based on kind of gas set (Parameter Fty).

Parameter Fty	Code	Temperature range	Parameter Fty	Code	Temperature range
0	R404	-50 ÷ 70 °C	11	R449A	-50 ÷ 70 °C
1	R134A	-50 ÷ 70 °C	12	R290	-50 ÷ 70 °C
2	R22	-50 ÷ 70 °C	13	R32	-50 ÷ 70 °C
3	R407A	-50 ÷ 70 °C	14	R448A	-50 ÷ 70 °C
4	R407F	-50 ÷ 70 °C	15	R452A	-50 ÷ 70 °C
5	R407H	-50 ÷ 70 °C	16	R600	-20 ÷ 70 °C
6	R410A	-50 ÷ 70 °C	17	R600A	-30 ÷ 70 °C
7	R450A	-40 ÷ 70 °C	18	R1270	-50 ÷ 70 °C
8	R507	-50 ÷ 70 °C	19	R1234ZE	-30 ÷ 70 °C
9	R513A	-45 ÷ 70 °C	20	R23	-50 ÷ 25 °C
10	R744 (CO ₂)	-50 ÷ 40 °C	21	R717 (NH ₃)	-50 ÷ 70 °C

CHAPTER 6: OPTIONS

6.1

TELENET MONITORING/SUPERVISION SYSTEM

In order to connect the board to the **TeleNET** network, follow the diagram below. Configure the instrument with reference to the **TeleNET** manual.

IMPORTANT: During configuration of the “Module”, select “Instrument NANO CHILLER” for the full control, or “Instrument TWMT” or “Instrument TWMP” according to the type of probe, according to the following table:

Address	Type of instrument to be created in the Telenet	Value read
Ad	TWMT	NTC 1probe (ambient temperature)
Ad	TWMP	4-20 mA condensation pressure
Ad + 1	TWMT	NTC 2 probe (antifreeze)
Ad + 2	TWMT	NTC 3 probe (external environment probe)
Ad + 3	TWMT	NTC 4 probe (condenser probe)

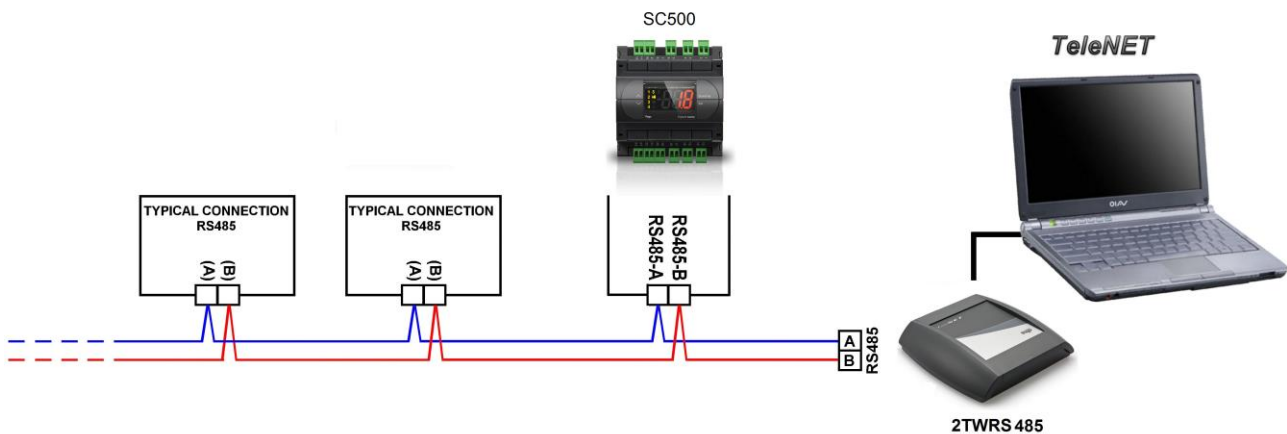

CHAPTER 7: DIAGNOSTICS

DIAGNOSTICS

7.1

In case of anomalies, the **DIN NANO CHILL** controller warns the operator using alarm codes shown by the display and an acoustic signal emitted by a buzzer inside the Operational console.

When there is an alarm, the  icon starts flashing on the display, the alarm relay is activated (if enabled), as well as the internal buzzer and one of the alarm codes is displayed (the code is alternated with the page normally displayed).

The internal buzzer can be silenced at any time by pressing the "Sound off" key. Press the SET key to reset the audio signal. If an alarm has been silenced and another kind of alarm is tripped (a different one from the one currently reported), the audio signal goes off again and the error code will be shown based on the display priority.

There can be two kinds of alarm based on how serious they are:

- Automatic reset (the alarm is automatically reset when the problem is cleared);
- Manual reset from the keyboard (the alarm is reset once it has been acquired by the operator via the "Sound off" key).

When the alarm is cleared, the icon stops flashing and becomes steady to tell the operator that an alarm with an automatic reset was tripped and is no longer activated. The display goes back to showing the normal page and the alarm code is no longer shown. When the "Sound off" key is pressed, the steady  icon turns off. The alarm code with the top priority tripped is saved and can be displayed (read-only) in the first-level ALL variable.

ALARM CODE TABLE:

COD.	POSSIBLE CAUSE / DESCRITPION	ACTION	ACTION TO BE TAKEN
OFF	Stand-by active	Plant stops and display flashes "OFF" and pressure value.	To restart the system, press the "Stand-by" key
InS	Remote stand-by active (digital input)	Plant stops and display flashes "InS" and pressure value.	Automatic restart, when digital input is deactivated
E0	EEPROM ALARM An error was found in the EEPROM memory. (The outputs are all disabled apart from the alarm outputs)	All outputs are deactivated.	<ul style="list-style-type: none"> • Switch the appliance off and back on • If the problem persists, replace the Control Circuit Board
E1	Functional malfunction of the NTC probe 1 - evaporator evaporator water inlet (room temperature)	All outputs are deactivated.	<ul style="list-style-type: none"> • Check probe status
E2	Wrong configuration or functional anomaly of the NTC 2 antifreeze probe	All outputs are deactivated.	<ul style="list-style-type: none"> • Check probe status • Check AOU, A1L, An2 parameters
E3	Wrong configuration or functional anomaly of the NTC 3 probe - external environment (condensation control) Wrong configuration of energy saving probes.	The energy saving function for the condenser is deactivated	<ul style="list-style-type: none"> • Check probe status • Check dAt, An3 parameters

COD.	POSSIBLE CAUSE / DESCRIPION	ACTION	ACTION TO BE TAKEN
E4	Wrong configuration or functional anomaly of the condenser water / air probe (condensation control)	All outputs are deactivated.	<ul style="list-style-type: none"> • Check probe status • Check AOU, CPd, An4 parameters
EFL	Flow switch alarm	All outputs are deactivated.	<ul style="list-style-type: none"> • Check the status of the water circuit • Manual reset by putting in stand-by
EFE	Thermal protection of the evaporator water pump	All outputs are deactivated.	<ul style="list-style-type: none"> • Check the pump status • Check the absorption of the pump
EFc	Thermal protection of condenser fans / pump	All outputs are deactivated.	<ul style="list-style-type: none"> • Check the fan / pump status • Check the absorption of the fan
EPH	Maximum pressure switch alarm, from digital input	All compressor outputs are deactivated.	<ul style="list-style-type: none"> • Check the refrigerant circuit
EPL	Minimum suction pressure switch alarm, from digital input	All outputs are deactivated.	<ul style="list-style-type: none"> • Check the refrigerant circuit
EH	Maximum temperature alarm	The outputs remain unchanged.	<ul style="list-style-type: none"> • Check the refrigerant circuit
EL	Minimum temperature alarm	All compressor outputs are deactivated.	<ul style="list-style-type: none"> • Check the refrigerant circuit
ELE	Minimum evaporator water delivery temperature alarm (antifreeze), temperature probe or digital input	All outputs are deactivated.	<ul style="list-style-type: none"> • Check the status of the evaporator
EHc	Maximum condensation pressure/temperature alarm	The compressor outputs are deactivated; the condenser fans remain unchanged.	<ul style="list-style-type: none"> • Check the condition of the condenser • Check the absorption of the fan
ELc	Minimum condensation pressure/temperature alarm	The condenser fan control outputs are deactivated	<ul style="list-style-type: none"> • Check the condition of the condenser • Check the absorption of the fan
EC1 EC2 EC3 EC4	Protection of one or more compressor outputs (eg Thermal protection or pressure switch of max.)	The output of the relative compressor is deactivated.	<ul style="list-style-type: none"> • Check the status of the compressor (s) • Check the absorption of the compressor (s) • Check the status of the "output alarm #." Input.
Err	Alarm signal in display only, from digital input	The outputs remain unchanged.	<ul style="list-style-type: none"> • Check the status of the compressor (s) • Check the status of the "display only alarm" input

COD.	POSSIBLE CAUSE / DESCRITPION	ACTION	ACTION TO BE TAKEN
E05	One or more outputs have reached the operating hours after which maintenance is required (Man parameter)	The outputs remain unchanged.	<ul style="list-style-type: none"> • Perform maintenance and reset the counter of the related digital output
E6	Low battery alarm; the control will work for at least another 20 days, then if the power supply to the panel is lost, the time setting will be lost	The outputs remain unchanged.	<ul style="list-style-type: none"> • Replace the battery
En	Communication error between the ECHO display and the Master		<ul style="list-style-type: none"> • Switch the appliance off and back on. • If the problem persists contact the technical assistance service.

ATTACHMENTS

A.1

EU DECLARATION OF CONFORMITY

**LA PRESENTE DICHIARAZIONE DI CONFORMITA' E' RILASCIATA SOTTO LA RESPONSABILITA' ESCLUSIVA DEL FABBRICANTE:
THIS DECLARATION OF CONFORMITY IS ISSUED UNDER THE EXCLUSIVE RESPONSIBILITY OF THE MANUFACTURER:**



PEGO S.r.l. a socio unico - Via Piacentina 6/b, 45030 Occhiobello (RO) – Italy –
Società soggetta all'attività di direzione e coordinamento di Castel S.r.l.

DENOMINAZIONE DEL PRODOTTO IN OGGETTO / DENOMINATION OF THE PRODUCT IN OBJECT

MOD.: NANO DIN CHILL

**IL PRODOTTO DI CUI SOPRA E' CONFORME ALLA PERTINENTE NORMATIVA DI ARMONIZZAZIONE DELL'UNIONE EUROPEA:
THE PRODUCT IS IN CONFORMITY WITH THE RELEVANT EUROPEAN HARMONIZATION LEGISLATION:**

Direttiva Bassa Tensione (LVD): 2014/35/UE
Low voltage directive (LVD): 2014/35/EU

Direttiva EMC: 2014/30/UE
Electromagnetic compatibility (EMC): 2014/30/EU

**LA CONFORMITA' PRESCRITTA DALLA DIRETTIVA E' GARANTITA DALL'ADEMPIMENTO A TUTTI GLI EFFETTI DELLE SEGUENTI NORME:
THE CONFORMITY REQUIRED BY THE DIRECTIVE IS GUARANTEED BY THE FULFILLMENT TO THE FOLLOWING STANDARDS:**

Norme armonizzate: EN 61010-1:2010, EN 61326-1:2013
European standards: EN 61010-1:2010, EN 61326-1:2013

Firmato per nome e per conto di:
Signed for and on behalf of:

Pego S.r.l.
Martino Villa
Presidente

Luogo e Data del rilascio:
Place and Date of Release:

Occhiobello (RO), 01/01/2024

CONNECTION LAYOUT

A.2

Power supply

PIN	DESCRIPTION
1 – 2	N – L Power supply 230Vac ±10% 50/60Hz Consumption: 5 VA max.

TeleNET

PIN	DESCRIPTION
18	line A or terminal 3 della TWRS485
19	line B or terminal 4 della TWRS485

Analog output

PIN	DESCRIPTION
20 (-) 21 (+)	Output 0-10V evaporator / condenser water pump inverter

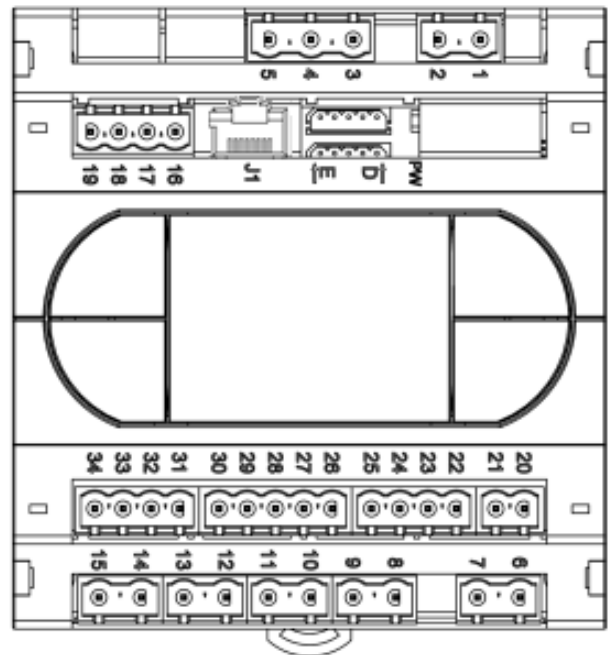

Digital outputs

PIN	RELAY OUTPUTS FEATURES (Voltage free contacts)	DESCRIPTION
6 – 7 (DO1)	relay 8A AC1 10 (10) A 250V~ (AC3)	Out 1: configurable
8 – 9 (DO2)	relay 16A AC1 10 (4) A 250V~ (AC3)	Out 2: configurable
10 – 11 (DO3)	relay 16A AC1 10 (4) A 250V~ (AC3)	Out 3: configurable
12 – 13 (DO4)	relay 16A AC1 10 (4) A 250V~ (AC3)	Out 4: configurable
14 – 15 (DO5)	relay 8A AC1 10 (4) A 250V~ (AC3)	Out 5: configurable

Analog input

PIN	TYPE OF PROBE	DESCRIPTION
26 - 27	NTC	Evaporator water inlet (ambient temperature) – NTC1
28 (In) – 30 (V+)	4–20 mA	Condenser pressure probe (J1 closed)
31 – 34	NTC	Antifreeze probe – NTC2
32 – 34	NTC	External environment probe(energy saving) – NTC3
33 - 34	NTC	Condensing temperature probe – NTC4

Digital inputs
(free voltage contacts)

PIN TERMINAL	DESCRIPTION
25 – 24	Digital input DI1
25 – 23	Digital input DI2
25 – 22	Digital input DI3
34 – 32	Digital input DI4
34 - 33	Digital input DI5



PEGO s.r.l.
Via Piacentina, 6/b 45030 Occhiobello (RO) – ITALY
Tel. +39 0425 762906
e-mail: info@pego.it – www.pego.it

TECHNICAL ASSISTANCE
Tel. +39 0425 762906 e-mail: tecnico@pego.it

Distributor: