

200NDINSC500



Use and maintenance manual

ENGLISH

READ AND KEEP

REV. 01-19
ENG

ELECTRICAL BOARDS FOR REFRIGERATING INSTALLATIONS



TABLE OF CONTENTS

INTRODUCTION

CHAP. 1

Pag. 3	1.1	Generality
Pag. 4	1.2	Product identification codes
Pag. 4	1.3	Overall clearances
Pag. 4	1.4	Identification data

INSTALLATION

CHAP. 2

Pag. 5	2.1	Main warnings for the installer
Pag. 5	2.2	Standard equipment for assembly and use
Pag. 6	2.3	Board installation

FUNCTIONALITY

CHAP. 3

Pag. 7	3.1	Functions managed by DIN SC500
--------	-----	--------------------------------

TECHNICAL FEATURES

CHAP. 4

Pag. 8	4.1	Technical features
Pag. 9	4.2	Warranty conditions

DATA PROGRAMMING

CHAP. 5

Pag. 10	5.1	Control panel
Pag. 10	5.2	Front keyboard
Pag. 11	5.3	LED Display
Pag. 12	5.4	Keys combination
Pag. 13	5.5	Generality
Pag. 13	5.6	Symbols
Pag. 13	5.7	Setpoint setting and displaying
Pag. 13	5.8	First level programming
Pag. 14	5.9	List of first level programming variables
Pag. 15	5.10	Second level programming
Pag. 15	5.11	List of second level programming variables
Pag. 18	5.12	Third level programming
Pag. 18	5.13	List of third level programming variables
Pag. 20	5.14	Sequence and activation delays
Pag. 20	5.15	Input and output configuration
Pag. 21	5.16	Operating mode –inverter management
Pag. 29	5.17	Operating mode – compressors capacity management
Pag. 32	5.18	Password function
Pag. 32	5.19	Temperature table for refrigerant fluids

OPTIONS

CAP. 6

Pag. 33	6.1	Supervision/monitoring system TeleNET
---------	-----	---------------------------------------

DIAGNOSTIC

CAP. 7

Pag. 34	7.1	Diagnostic
Pag. 37	7.2	Alarm history management

ATTACHMENTS

Pag. 38	A.1	EU Declaration of conformity
Pag. 39	A.2	Electrical connections

CHAPTER 1: INTRODUCTION

GENERALITY

1.1

The **NANO DIN SC500** system allows users to control the machine room of a refrigeration plant in which there is more than one compressor. It guarantees uniform operation and proper distribution of operating times among individual machines. All functions are performed in complete safety and the Control Console (REMOTE NANO DISPLAY) can be installed anywhere, independently of where the power cabinet is located.

APPLICATIONS:

- Compressor and condenser fan control of a refrigeration plant.

MAIN FEATURES:

- Configurable for control of compressors (up to a maximum of 5) or condenser fans (up to a maximum of 5). It's possible to configure the outputs by setting the number of compressors or fans to control.
- Configurable for compressor partition valves control.
- 0-10V Analog output for compressor inverter control or for the adjustment of fan speed in alternative to digital outputs control of the condenser fans.
- Display of the pressure probe measure in Bar or in °C (conversion based on the type of refrigerant gas selected).
- Rotation of compressors / fans according to the time of operation.
- Management compressors of different or the same powers.
- Side band regulation.
- Configurable digital inputs
- Night / day management (energy saving).
- Clock and calendar.
- Alarm recording
- Password for keys lock.
- RS485 Serial connection (Modbus-RTU or Telenet protocol).
- Pego programming philosophy that guarantees an immediate start-up.

1.2

PRODUCT IDENTIFICATION CODES

200NDINSC500

Compressor and condenser fan control of a refrigeration plant.

1.3

OVERALL CLEARANCES

Dimensions in mm

DISPLAY NANO SC500

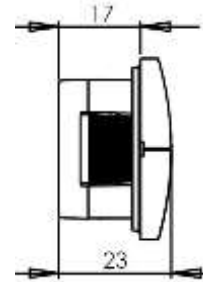
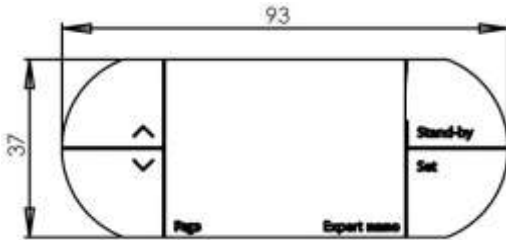

MASTER SC500

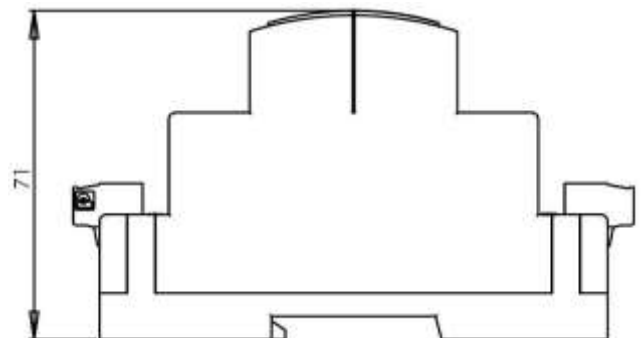
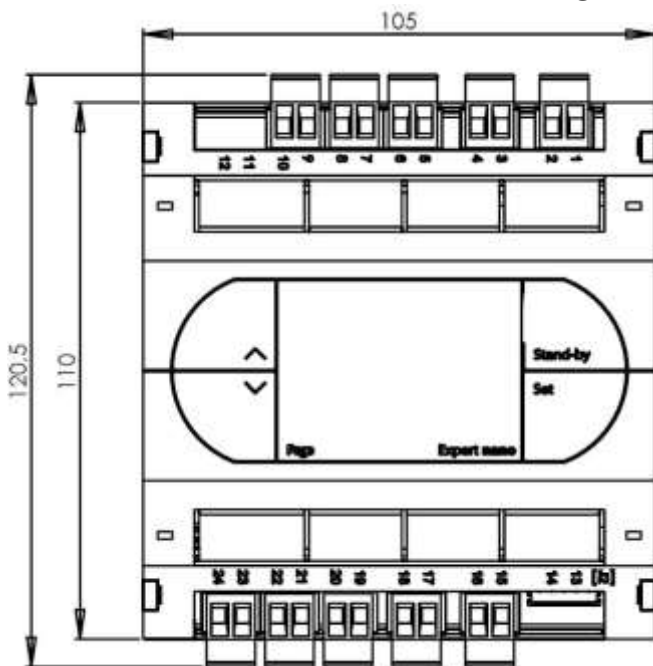

1.4

IDENTIFICATION DATA

The equipment described in this manual is provided with an identification data plate of the same placed on one side:

- Name of Manufacturer
- Equipment code
- Serial number
- Power supply voltage



CHAPTER 2: INSTALLATION

MAIN WARNINGS FOR THE INSTALLER

2.1

1. Install the equipment in places complying with the protection degree and keep the box as intact as possible when making holes to house the cable glands and/or conduit glands;
2. Avoid using multicore cables with conductors connected to inductive and power loads and signal conductors which probes and digital inputs;
3. Avoid housing power supply cables with signal cables (probes and digital inputs) in the same conduit
4. Reduce the lengths of the connection cables as much as possible, avoiding the wiring assuming the spiral shape, damaging for possible inductive effects on the electronics;
5. All conductors used in the wiring must be suitably proportioned to support the load to be powered;
6. Provide a main protection fuse upstream of the electronic control;
7. If required to extend the probes, use conductors with suitable section and not below 1mm². The extending or shortening of the probes may alter the factory calibration; use an external thermometer to check and calibrate.

STANDARD EQUIPMENT FOR ASSEMBLY AND USE

2.2

For assembly and use, the electronic controller **DIN NANO SC500** is equipped with:

- N° 1 Telephone plug cable;
- N° 1 Use manual;
- N° 1 DIN NANO SC500 (200NDINSC500);

2.3

INSTALLATION

Fig.1: Position the module on the DIN guide and close the lower hook to lock it on the same.

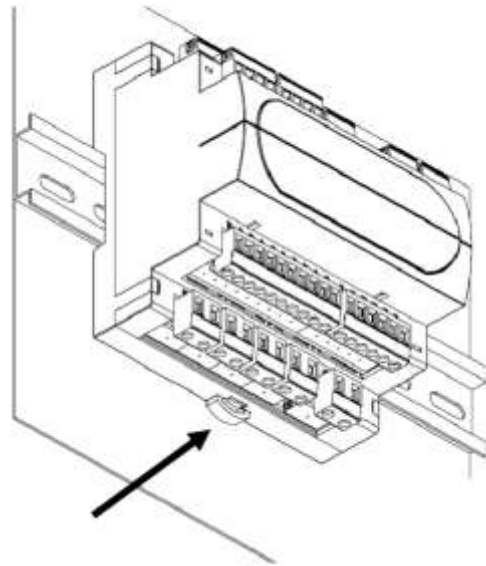

Fig.2: Fix the **NANO SC500** console using the two screws to be inserted in the slots underneath the keys frame.

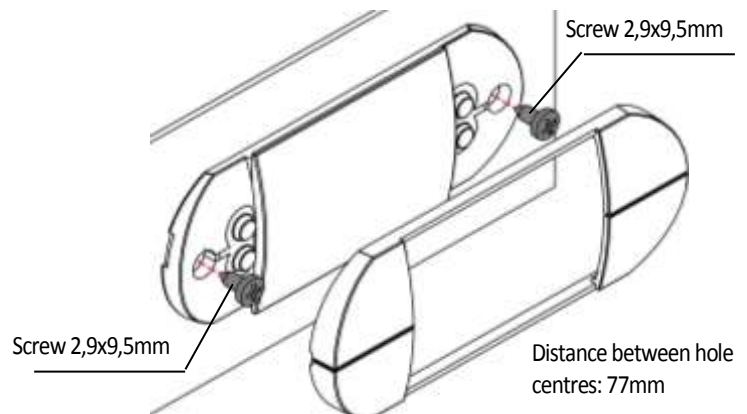

Fig.3: **NANO SC500** console perforation template.



CHAPTER 3: FUNCTIONALITY**FUNCTIONS MANAGED BY DIN NANO SC500****3.1**

- Compressor control of a refrigeration plant, up to a maximum of 5 or, alternatively, condenser fan control of a refrigeration plant, up to a maximum of 5.
- Compressor partition valves control. Each compressor output is associated to another output to control the corresponding partition valve (NC or NO).
- Sideband compressors and fans regulation.
- Analog output 0-10V for compressor inverter management. Compressor relay outputs are still controlled.
- 0-10V Analog output for the adjustment of fan speed in alternative to digital outputs control of the condenser fans.
- Rotation of compressors / fans according to the time of operation.
- Management compressors of different or the same powers.
- Clock and calendar.
- RS485 Serial connection (Modbus-RTU or Telenet protocol).
- Alarm history management. You can view the last highest priority alarm occurred, or the list of the last 40 alarms with their time or date of activation.
- Alarm relay configurable (if enabled, you can manage up to a maximum of 4 compressor / fan outputs).
- Remote Stand-by digital input.

CHAPTER 4: TECHNICAL FEATURES

4.1

TECHNICAL FEATURES

Power supply	
Model 200NDINSC500	230V~ +10/-15% 50/60Hz
Max. absorbed power (electronic control only)	5 VA Max
Climatic Conditions	
Work temperature	-5T50°C - humidity < 90% U.R. Not condensing
Storage temperature	-10T70°C - humidity < 90% U.R. Not condensing
Unsuitable operating environments	Environments with strong vibrations or impacts; aggressive, polluted or corrosive atmospheres, exposure to direct solar radiation, explosive atmospheres or flammable gas.
General characteristics	
Display	3-Digit with sign, decimal point and 9 LED status indicators
Model 200NDINSC500	Power clamps: extractable, screw for cables with c/section 0.2 to 2.5mm ²
Software class: A / Parameters saved on non-volatile memory (EEPROM)	
Input characteristics	
Analogue inputs	1 pressure probe : 4/20mA configurable
Digital inputs	7 inputs (clean contact)
Output characteristics	
Relay 1 (DO1)	N.O. 8(6)A / 250V~
Relay 2 (DO2)	N.O. 16(3)A / 250V~
Relay 3 (DO3)	N.O. 16(6)A / 250V~
Relay 4 (DO4)	N.O. 16(6)A / 250V~
Relay 5 / allarme (DO5)	N.O. 8(3)A / 250V~
Buzzer	Present
Dimensional, insulation and mechanical characteristics	
Dimensions	Master : 105x121.5x71mm Display : 93x37x23mm
Drill hole template (display 485)	71x29mm (+0,2/-0,1mm)
Protection rating (display 485)	IP65 with front board installation
Installation (display Echo 485)	In front of board by side tabs fixing or by two front screws
Installation Master	Din rail 35mm
Casing	Plastic PC+ABS UL94 V-0 body, PC transparent front, Key panel PC or PC+ABS
Insulation type	Class II
Conformity with EEC low voltage directives, electromagnetic compatibility and EC mark	
Conforms to following EEC Directives : Directives 2014/30/EU, 2014/35/EU Conforms to following harmonised standards: EN60730-1:2016, EN60730-2-9:2010, EN61000-6-1:2007, EN61000-6-3:2007	

WARRANTY CONDITIONS

4.2

The **DIN NANO SC500** series electronic controls are covered by a 24-months warranty against all manufacturing defects as from the date indicated on the product ID code.

In case of defect the product must be appropriately packaged and sent to our production plant or to any authorized Service Center with the prior request of the Return Authorization Number.

Customers are entitled to have defective products repaired, spare parts and labour included. The costs and the risks of transport are at the total charge of the Customer. Any warranty action does not extend or renew its expiration.

The Warranty does not cover:

- Damages resulting from tampering, impact or improper installation of the product and its accessories.
- Installation, use or maintenance that does not comply with the instructions provided with the product.
- Repair work carried out by unauthorized personnel.
- Damage due to natural phenomena such as lightning, natural disasters, etc...

In all these cases the costs for repair will be charged to the customer.

The intervention service in warranty can be refused when the equipment is modified or transformed.

Under no circumstances **Pego S.r.l.** will be liable for any loss of data and information, costs of goods or substitute services, damage to property, people or animals, loss of sales or earnings, business interruption, any direct, indirect, incidental, consequential, damaging, punitive, special or consequential damages, in any way whatsoever caused, whether they are contractual, extra contractual or due to negligence or other liability arising from the use of the product or its installation.

Malfunction caused by tampering, bumps, inadequate installation automatically declines the warranty. It is compulsory to observe all the instructions in this manual and the operating conditions of the product.

Pego S.r.l. disclaims any liability for possible inaccuracies contained in this manual if due to errors in printing or transcription.

Pego S.r.l. reserves the right to make changes to its products which it deems necessary or useful without affecting its essential characteristics.

Each new release of the Pego product user manual replaces all the previous ones.

As far as not expressly indicated, is applicable the Law and in particular the art. 1512 C.C. (Italian Civil Code).

For any controversy is elected and recognized by the parties the jurisdiction of the Court of Rovigo.

CHAPTER 5: DATA PROGRAMMING



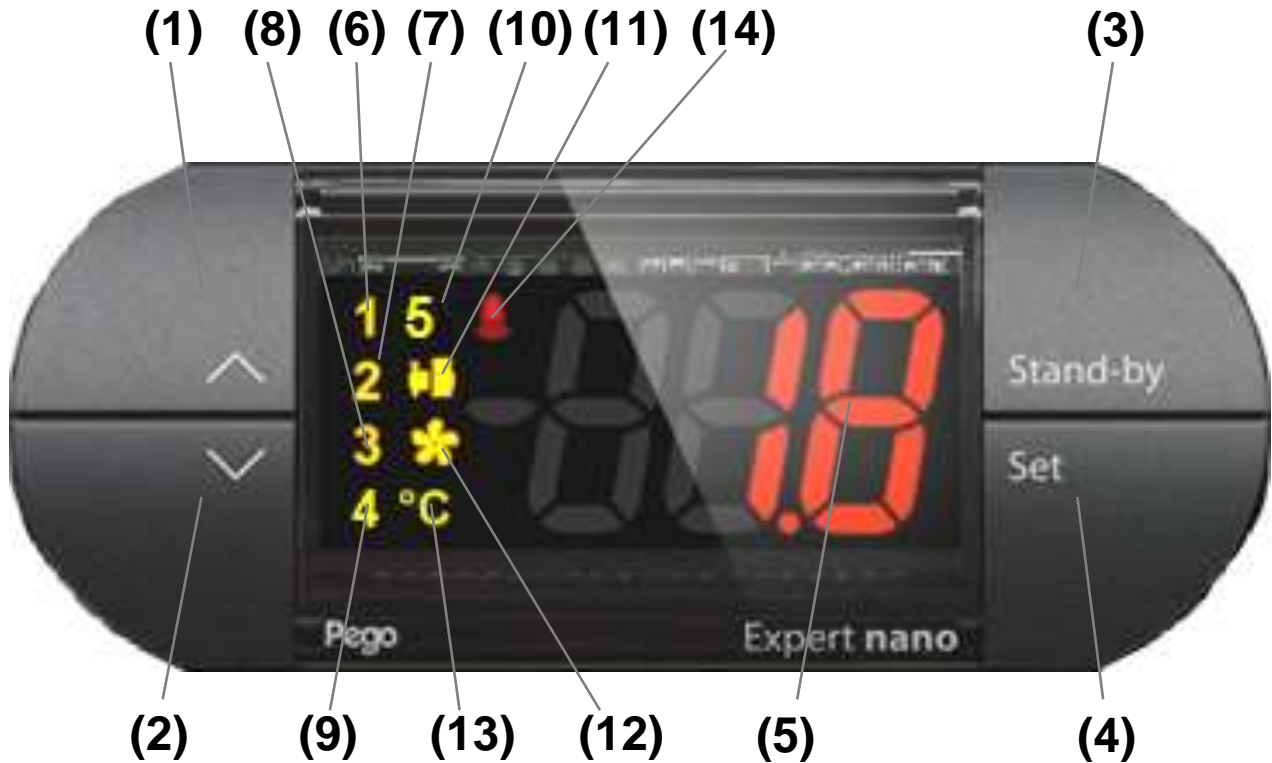

5.1

CONTROL PANEL

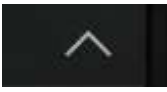

5.2

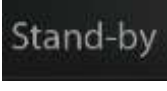
FRONT KEYBOARD

- (1)  **UP**
Increases the values / Scroll up the parameters
Reset sound alarm if any.
If pressed more than 3 seconds displays the alarm history.
-
- (2)  **DOWN**
Decreases the values / Scroll down the parameters.
-
- (3)  **STAND BY**
If pressed for over 1 second alternates the Stand-By with normal mode and vice versa.
In Stand-By mode the system stops and the display signals OFF and the current view.
If pressed together with the SET button, switches the display from °C to Bar.
-
- (4)  **SET**
View the setpoint.
Allows you to set the compressors setpoint when pressed in combination with the Up or Down button.

LED DISPLAY

5.3

(5)



View values / parameters

(6)

**"OUTPUT 1" ICON**

LED ON = Digital output 1 ON

Flashing Led = Digital Output 1 pending the delays for the passage from on/off or off/on..

(7)

**"OUTPUT 1" ICON**

LED ON = Digital output 1 ON

Flashing Led = Digital Output 1 pending the delays for the passage from on/off or off/on..

(8)

**"OUTPUT 1" ICON**

LED ON = Digital output 1 ON

Flashing Led = Digital Output 1 pending the delays for the passage from on/off or off/on..

(9)

**"OUTPUT 1" ICON**

LED ON = Digital output 1 ON

Flashing Led = Digital Output 1 pending the delays for the passage from on/off or off/on..

(10)

**"OUTPUT 1" ICON**

LED ON = Digital output 1 ON

Flashing Led = Digital Output 1 pending the delays for the passage from on/off or off/on..

(11)

**"COMPRESSOR CONTROL" ICON**

LED ON = Compressor control ENABLED (at least one compressor ON)

(12)

**"CONDENSER FAN CONTROL" ICON**

LED ON = Condenser Fan Control ENABLED (at least one fan ON)

(13)

**"UNIT OF MEASURE IN DEGREES CELSIUS" ICON**

LED ON = Unit of measure in degrees Celsius of the viewed value

(14)

**ALARM IN PROGRESS ICON**

LED OFF = No alarm triggered

LED ON = Alarm triggered and then cancelled

Blinking LED = Alarm in progress

**EXIT PROGRAMMING**

If pressed simultaneously for more than 3 seconds within any programming menu or the historical alarm allow you to exit the menu.

Exit from menu generates a confirmation beep.

**1st LEVEL PROGRAMMING**

If pressed simultaneously for more than 3 seconds allowing access to the first level programming menu (if you are not in programming). Exit from this menu takes place automatically after 30 seconds of keyboard inactivity or by pressing up arrow + down arrow (confirmation beep output).

**2nd LEVEL PROGRAMMING**

If pressed simultaneously for more than 3 seconds allowing access to the second level programming menu.

At the entrance of the menu a confirmation beep is generated.

**3rd LEVEL PROGRAMMING**

If pressed simultaneously for more than 3 seconds allowing access to the third level programming menu.

At the entrance of the menu a confirmation beep is generated.

**OUTPUT HOUR COUNTER / ALARM HISTORY RESET**

While viewing the working time of an output within the read-only Hr1, Hr2, Hr3, Hr4, Hr5 parameters while pressing the SET key and pressing the STAND-BY for at least 10 seconds, the hour counter will be reset.

Similarly while viewing the alarm history while pressing the SET key and pressing the STAND-BY for at least 10 seconds, the alarm history will be reset

SWITCHING FROM Bar to °C

While viewing several variables in Bar, pressing the stand-by key and Set together switches the view from Bar to °C according to the table of the gas type selected until the keys are released.

The variables involved with this kind of view are:

- **Setpoint, r0, LSE, HSE.**

**ALARM HISTORY**

If pressed for more than 3 seconds allowing access to the alarm history menu (if you are not in programming). Exit from this menu takes place automatically after 30 seconds of keyboard inactivity or by pressing up arrow + down arrow (confirmation beep output).

GENERALITY



5.5

For operator safety and practicality, the **NANO DIN SC500 system** envisions three programming levels; the first for configuration of the frequently amendable **SETPOINT** parameters only, the second for programming and setting of the main parameters relating to the various board functioning modes and the third for programming input/output of the board. It is not possible to directly access the second or third level from first level programming, exit current programming first.

SYMBOLS

5.6

For practicality we will use the following symbols:

- (▲) the UP key  that performs value increase functions;
- (▼) the DOWN key  that performs value decrease functions.

SETPOINT SETTING AND DISPLAYING

5.7

1. Press the SET key to display the current SETPOINT in Bar.
2. Keeping the SET key pressed and pressing one of the (▲) or (▼) keys, the SETPOINT value can be amended. Release the SET key to return to displaying the regulation probe value; memorising of the made amendments will automatically happen. While viewing the SET POINT value in Bar (SET button pressed), if you press the standby key at the same time, you will view the value changed to °C depending on the type of Gas set. While viewing the value in °C, it will not be possible to change the set through the arrows.

LEVEL 1 PROGRAMMING (User level)

5.8

To access Level 1 programming, press and hold the UP key (▲) and DOWN key (▼) for over 3 seconds.

When the first programming variable appears:

1. Select the variable you want to change with the key (▲) or with the key (▼). After selecting the required variable, it is possible to:
2. View its configuration by pressing the SET key.
3. Edit configuration by pressing and holding the SET key and pressing either the (▲) or (▼) key.
4. After setting the configuration values, press and hold both the (▲) key and the (▼) key for a few seconds until the cell temperature value appears and exit the menu. The system closes the menu when the keypad is not used for over 30 seconds.
5. Any changes made to the variables are saved automatically when the system closes the configuration menu.

5.9

LIST OF LEVEL 1 VARIABLES (User Level)

LABEL	MEANING	VALUES	DEFAULT
r0	SET differential of the pressure (interlocked with nC or nU)	0,2 ÷ 30,0 bar Step 0,2 Bar	0,6 Bar
t1	The minimum time that must elapse between the insertion of a step and the next one (SECONDS) This time avoids breakaways caused by simultaneous start-ups.	2 ÷ 500 sec step 2 sec	20 sec
t2	The minimum time that must elapse between two different step deactivations. (SECONDS)	2 ÷ 500 sec step 2 sec	10 sec
t3	The minimum time that must elapse between two successive insertions of the same step. (SECONDS)	2 ÷ 500 sec step 2 sec	320 sec
t4	The minimum time that must elapse between one shutdown and the next insertion of the same step. (SECONDS)	2 ÷ 500 sec step 2 sec	2 sec
Fty	Type of refrigerant GAS in use. The setting of this parameter is essential for correct operation	0 = R404 11 = R449A 1 = R134 12 = R290 2 = R22 13 = R32 3 = R407A 14 = R448A 4 = R407F 15 = R452A 5 = R407H 16 = R600 6 = R410A 17 = R600A 7 = R450A 18 = R1270 8 = R507 19 = R1234ze 9 = R513A 20 = R23 10=R744(CO2) 21=R717(NH3)	0
UM	View unit of measurement	0 = °C 1 = Bar	1
AO	Display of the 0-10V analogue output	0,0 – 10,0V if iEn=0 displays - - -	Read only
ALL	View of the last alarm triggered	Alarm code	Read only
A1	Minimum pressure alarm The absolute pressure referring to the pressure probe below which, once the Ald delay time is activated, the LOW pressure alarm is triggered showing ELc if compressor mode (or ELu if condenser fan mode) alternating with the pressure on the display and the flashing of the alarm icon. When the alarm turns off, the "alarm presence" icon will remain lit to indicate which operation has occurred until the up button is pressed.	-0,6 ÷ (A2-0,2) Bar, step 0,2 Bar	-0,6 bar

A2	Maximum compressor pressure alarm The absolute pressure referring to the pressure probe above which, once the Ald delay time is activated, the HIGH pressure alarm is triggered showing EHc if compressor mode (or EHu if condenser fan mode) alternating with the pressure on the display and the flashing of the alarm icon. When the alarm turns off, the "alarm presence" icon will remain lit to indicate which operation has occurred until the up button is pressed.	$(A1+0,2) \div +90,0$ Bar, step 0,2 Bar	+30,0 bar
tdS	Day start time programming (ignored if dnE=0 or there is a night digital input)	00:00 ÷ 23:50 step 10 min	06:00
tdE	Day end time programming (ignored if dnE=0 or there is a night digital input)	00:00 ÷ 23:50 step 10 min	22:00

LEVEL 2 PROGRAMMING (Installer level)

5.10

To access Level 2 programming, press and hold the UP key (▲), DOWN key (▼) and STAND-BY key for over 3 seconds.

When the first programming variable appears:

1. Select the variable you want to change with the key (▲) or with the key (▼). After selecting the required variable, it is possible to:
2. View its configuration by pressing the SET key.
3. Edit configuration by pressing and holding the SET key and pressing either the (▲) or (▼) key.
4. After setting the configuration values, press and hold both the (▲) key and the (▼) key for a few seconds until the pressure value appears and exit the menu.
5. Any changes made to the variables are saved automatically when you release SET button.

LIST OF LEVEL 2 VARIABLES (Installer Level)

5.11

LABEL	MEANING	VALUES	DEFAULT
SEq	Logical selection of the digital outputs activation	0 = With rotation 1 = Without rotation	1
Man	Max. number (hours x 10) of operating hours for a compressor after which a request for maintenance will be signalled (if = 0, the request for maintenance will not be signalled)	0 ÷ 510 step 2	300
EP4	Pressure (bar) corresponding to 4mA.	-1,0 ÷ (EP2 - 0,1) Bar	0,0 Bar
EP2	Pressure (bar) corresponding to 20mA.	(EP4 + 0,1) ÷ 90,0 Bar	12,0 Bar
NiP	Time (hours) in which the activation of the manual central alarm is triggered 5 times. At the 5th activation, it remains in alarm.	0 ÷ 240 hours	6 hours

rLo	Time (min.) with which the freon/oil pre-alarm (Ep) becomes alarm (EF). Once this time has passed, all outputs are disabled.	0 ÷ 240 min	30 min
iOu Fans Inverter	Fans Inverter Offset (of pressure) Value always lower than the value of (r0)	0,5 ÷ 2,5 Bar always < r0	0,5 Bar
iMu Fans Inverter	Fans Inverter: setting the minimum value of the 0-10V output	0 ÷ 100 %	30 %
bOu Inverter fans	Fans Boost: Time for which the 0-10V output of the fans is forced to 100%. This serves to overcome the inrush current at their start. (SECONDS)	0 ÷ 240 sec	2 sec
iMc Inverter compressors	Compressors Inverter: setting the minimum value of the 0-10V output	0 ÷ 100 %	30 %
itS Inverter compressors	Minimum time to change analog output inverter compressor to go from 0 to 10V or 10 to 0V during activation or deactivation of compressors steps. (SECONDS)	0 ÷ 240 sec	60 sec
LSE	Minimum value that can be attributed to the set point	-0,5 ÷ (HSE-1) Bar	0,2 Bar
HSE	Maximum value that can be attributed to the set point	(LSE+1) ÷ 90,0 Bar	5,0 Bar
dnE	Night mode enable (energy saving) At night operation decimal point flashes.	0 = disabled 1 = enabled	0
nSC	Correction for the compressor SET during night operation (energy saving) During night operation the Compressor set is: Compressor Set = Set + NSC	-5,0 ÷ 5,0 Bar	0,0
Ald	Minimum or maximum pressure alarm signalling and display delay time.	0 ÷ 240 min	120 min
CAL	Pressure sensor calibration	-10,0 ÷ +10,0 step 0,1 Bar	0,0 Bar
BEE	Buzzer enable	0 = disabled 1 = enabled	1
Ad	Network address for connection to the TeleNET or Modbus supervision system (see par. 6.1)	0 ÷ 31 (with SEr=0) 1 ÷ 247 (with SEr=1)	1
SEr	RS-485 communication protocol	0 = TeleNET protocol 1 = Modbus-RTU protocol	0
bdr	Modbus baudrate.	0 = 300 baud 4 = 4800 baud 1 = 600 baud 5 = 9600 baud 2 = 1200 baud 6 = 14400 baud 3 = 2400 baud 7 = 19200 baud 8 = 38400 baud	5

Prt	Modbus parity checking	0 = no parity bit 1 = even parity bit 2 = odd parity bit	0
P1	Password: type of protection (active when PA is not 0)	0 = shows only the set point and permits deactivation of the alarms. 1= disables access to level 1, 2 and 3 programming and disables access to alarm history (access permitted to all other functions) 2= disables access to level 2 and 3 programming (access permitted to all other functions).	2
PA	Password (see P1 for the type of protection)	0 ÷ 999 0 = function disabled	0
Yr	Year setting (Date)	00 ÷ 99	16
Mo	Month setting (Date)	01 ÷ 12	01
dY	Day setting (Date)	01 ÷ 31	01
Hr	Hour setting (Time)	00 ÷ 59	12
min	Minute setting (Time)	00 ÷ 23	00
dEF	Reserved parameter	- - -	Read only
reL	Software release		Read only

5.12

LEVEL 3 PROGRAMMING (Installer level)

To access Level 3 programming, press and hold the UP key (▲) and STAND-BY key for over 3 seconds.

When the first programming variable appears:

1. Select the variable you want to change with the key (▲) or with the key (▼). After selecting the required variable, it is possible to:
2. View its configuration by pressing the SET key.
3. Edit configuration by pressing and holding the SET key and pressing either the (▲) or (▼) key.
4. After setting the configuration values, press and hold both the (▲) key and the (▼) key for a few seconds until the pressure value appears and exit the menu.
5. Any changes made to the variables are saved automatically when you release SET key.

5.13

LIST OF LEVEL 3 VARIABLES (Installer Level)

VAR	MEANING	VALUES	DEFAULT
iEn	Inverter enable: 0 = Management inverter disabled 1 = Management inverter enabled If nC > 0 Inverter compressor 1 (fan outputs and other compressors outputs are handled as digital outputs) If nU > 0 Inverter fans (All fans are parallel connected to the inverter)	0 ÷ 1 Note: if iEn>0 the parameter nPC is forced to 0 (compressors capacity disabled)	0
nC	Selecting number of compressor outputs. (nC = 0 if nU > 0)	0 ÷ 5 if NPC = 0 and rA = 0 0 ÷ 2 if NPC = 1 0 ÷ 4 if NPC = 0 and rA ≠ 0	5
nU	Selecting number of fan outputs. (nU = 0 if nC > 0)	0 ÷ 5 if rA = 0 0 ÷ 4 if rA ≠ 0	0
nPC	Compressor capacity-enabled (50%) (if inverter compressor disabled)	-1 = valve N.C. 0 = disabled 1 = valve N.A.	0
rA	Setting general alarm output	-1 = N.C. 0 = disabled 1 = N.A.	0
H1	Digital output 1 hour counter (resettable)*	0 ÷ 999 tens of hours	Read only
H2	Digital output 2 hour counter (resettable)*	0 ÷ 999 tens of hours	Read only
H3	Digital output 3 hour counter (resettable)*	0 ÷ 999 tens of hours	Read only
H4	Digital output 4 hour counter (resettable)*	0 ÷ 999 tens of hours	Read only
H5	Digital output 5 hour counter (resettable)*	0 ÷ 999 tens of hours	Read only

I1	Setting of digital input n.1	<p>18= Night mode digital input (energy saving) (N.O.) 17= Remote Stand-by (N.O.) 16= Low intake press. pressostat alarm EPL (NO) 15= High delivery press. pressostat alarm EPH(NO) 14= Freon level alarm (N.O.) 13= Central alarm in manual mode (N.O.) 12= Alarm display only - fans (N.O.) 11= Alarm display only - compress. (N.O.) 10= Fan alarm n.5 (N.O.) 9= Fan alarm n.4 (N.O.) 8= Fan alarm n.3 (N.O.) 7= Fan alarm n.2 (N.O.) 6= Fan alarm n.1 (N.O.) 5= Compressor alarm n.5 (N.O.) 4= Compressor alarm n.4 (N.O.) 3= Compressor alarm n.3 (N.O.) 2= Compressor alarm n.2 (N.O.) 1= Compressor alarm n.1 (N.O.) 0= Disabled -1= Compressor alarm n.1 (N.C.) -2= Compressor alarm n.2 (N.C.) -3= Compressor alarm n.3 (N.C.) -4= Compressor alarm n.4 (N.C.) -5= Compressor alarm n.5 (N.C.) -6= Fan alarm n.1 (N.C.) -7= Fan alarm n.2 (N.C.) -8= Fan alarm n.3 (N.C.) -9= Fan alarm n.4 (N.C.) -10= Fan alarm n.5 (N.C.) -11= Alarm display only - compress. (N.C.) -12= Alarm display only - fans (N.C.) -13= Central alarm in manual mode (N.C.) -14= Freon level alarm (N.C.) -15= High delivery pres. pressostat alarm EPH (NC) -16= Low intake press. pressostat alarm EPL (N.C.) -17= Remote Stand-by (N.C.) -18= Night mode digital input (N.C.)</p>	1
I2	Setting of digital input n. 2	as I1	2
I3	Setting of digital input n. 3	as I1	3
I4	Setting of digital input n. 4	as I1	4
I5	Setting of digital input n. 5	as I1	5
I6	Setting of digital input n. 6	as I1	13
I7	Setting of digital input n. 7	as I1	16

(*) Digital output operation times are reset by displaying the desired hour counter (Hr1, Hr2, ecc.) and pressing SET and STAND-BY simultaneously for at least 10 seconds. When this time has elapsed a beep confirms that the task has been completed.

5.14

ACTIVATION SEQUENCE AND DELAYS

The activation logic of the digital outputs is selected by parameter Seq (for both compressors and fans).

With **SEq=1**, the activation of digital outputs always follows the 1, 2, 3, 4, 5 sequence and the 5, 4, 3, 2, 1 disabling one complying with the **t1, t2, t3, t4** times. If an output is not available because it is alarm, it will be temporarily excluded from the sequence.

With **SEq=0** the activation/deactivation of the digital outputs is operation time-based, and in particular:

- The output that has the least number of operating hours in times **t1, t2, t3** and **t4**, and that is available at that time (therefore not in alarm).
- The output that has the largest number of operating hours in times **t1, t2, t3, t4** is deactivated.

Delays on the activations of the outputs

“**t1**” determines the minimum time that must elapse between the insertion of a step and the next one. This parameter avoids breakaways caused by simultaneous start-ups.

“**t2**” determines the minimum time that must elapse between the deactivation of two different steps.

“**t3**” determines the minimum time that must elapse between two subsequent insertions of the same step. This parameter allows you to limit the number of start-ups per hour if the controlled motors require this.

“**t4**” determines the minimum time that must elapse between one shutdown and the next insertion of the same compressor step.

On the display the icons relative to outputs (see par 5.3) will flash when its output is pending ON or OFF due to these times.

5.15

INPUTS AND OUTPUTS CONFIGURATION

The configuration of the outputs can be set via the nC, nU and NPC parameters. Each output can be associated with the relative protection via the I1, I2, ... , I7 digital inputs.

The nC, nU and NPC parameters are closely associated with each other. In particular, if the number of compressors (nC parameter) is different from zero, the number of fans is set to zero. If the number of fans (nU parameter) is different from zero, the number of compressors is set to zero. If the capacity control is activated (NPC=1 or -1), each compressor is associated with an additional output to check the relative splitting valve. You can configure up to 2 compressors with capacity control (50%). If the alarm relay is enabled (parameter rA nonzero) output 5 is used as an alarm output.

Recap:

- Compressor management mode:

	Maximum number of compressors that can be set (Parameter nC)
Active capacity control (nPC = 1 o -1)	2
Disabled capacity control (nPC = 0)	If rA different from 0 → 4
	If rA different from 0 → 5

- Fan management mode:

	maximum number of fans that can be set (Parameter nU)
Alarm relay enabled (rA = 1 o -1)	4
Alarm relay disabled (rA = 0)	5

Compressors have a sliding-based management: the first outputs are considered as “Compressor outputs”, followed by the “Capacity control outputs”. If, for instance, you set NPC=1, nC=2, then:

- outputs 1,2 are “Compressor outputs”
- outputs 3,4 are associated with the capacity control of the compressors.

OPERATING MODE –INVERTER MANAGEMENT

5.16

The operating mode is selected via the iEn parameter.

iEn = 0: inverter management deactivated

If iEn=0 the outputs are managed with digital outputs and side-band control.

Based on the value of the “SET”, "r0" and "nC/nU" parameters, the controller calculates the various areas where there is a request to enable and disable the compressor/fan outputs (steps) by positioning the various switch-ons and switch-offs in the r0 differential range. Each step has a r0/nC (or r0/nU) differential (where nC is the number of compressors and nU is the number of fans). The combination of the outputs to the steps depends on the setting of the Seq. variable. If, for instance, we consider Seq=1, for Compressor output no.2 the enabling will occur at SET +(r0/nC)*2 (constant 2 refers to step 2) and the disablings will occur at SET +(r0/nC)*1 (see graph no.1 or graph no.2).

The number of enabled compressors depends on the deviation between the value measured by the adjustment pressure sensor and the set Setpoint.

CONTROL IN THE EVENT OF ALARMS

With the presence of alarms (alarm outputs 1...nC or 1...nU alarm inputs enabled), operation is maintained equal but the output relating to the alarm in the sequence and the relative alarm is shown on the display (EC1...ECn or EU1...EUn).

CASE SEq=1

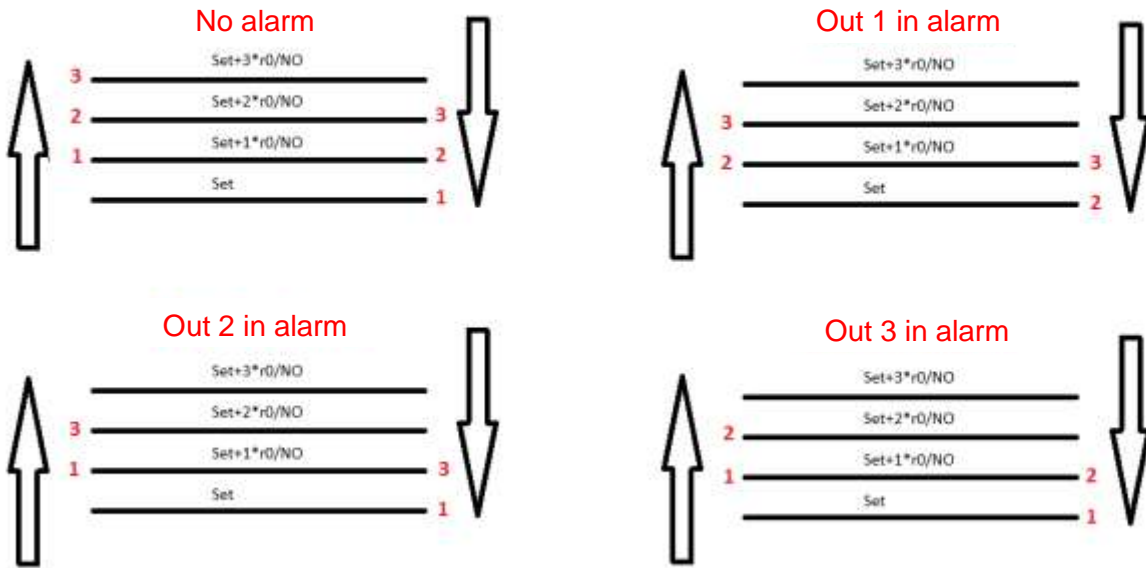

Set = Setpoint compressors / fans
 NO = compressors number nC / fans number nU

An output in alarm is re-enabled when the alarm ends, but is not activated if it is already in operation a number of compressors / fans equal to the number of steps required. After returning from the state of standby the outputs are activated respecting t1 and t3 time between ignition and another.

Graph n.1
 Example with $sEq=1, nC=3$

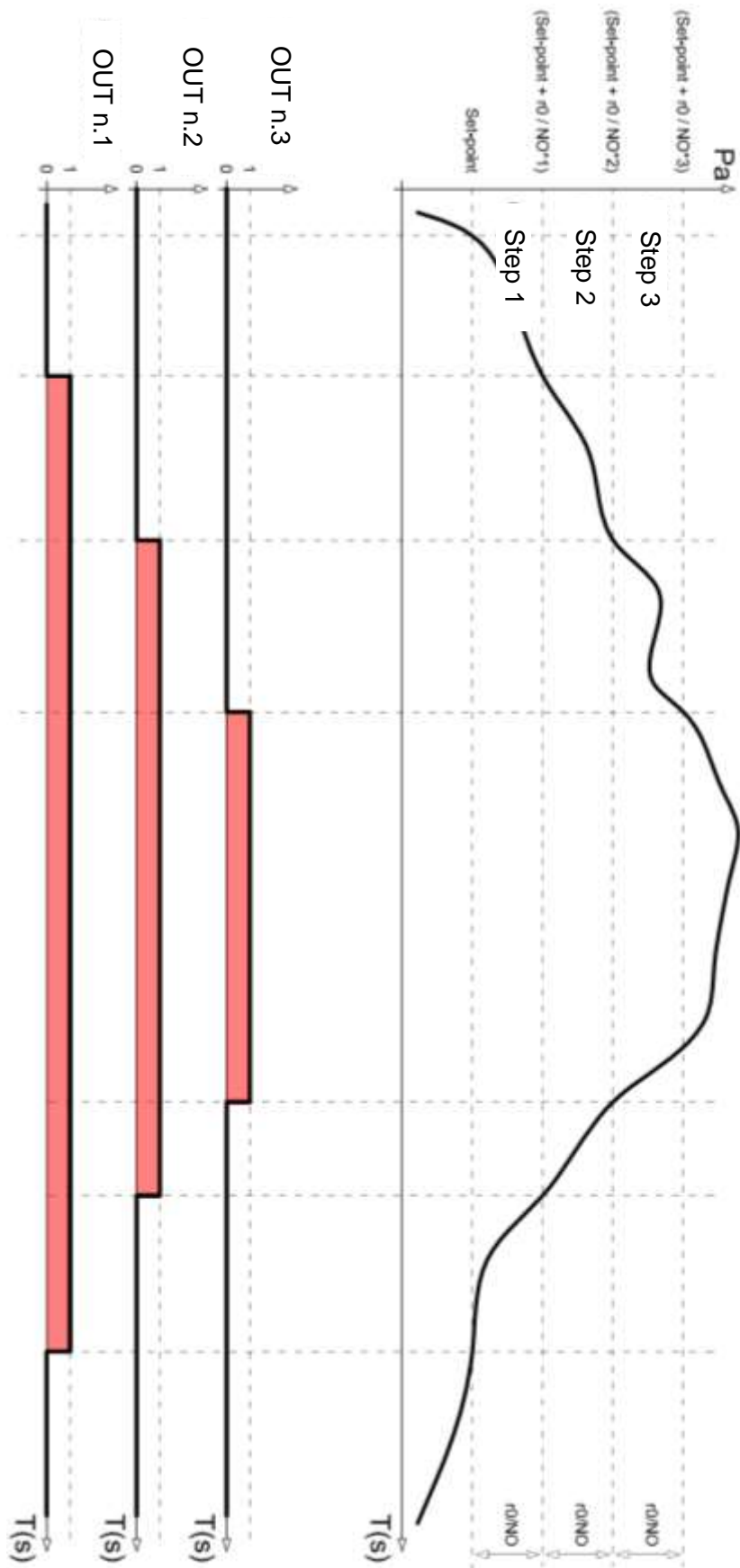

Example of sideband insertion, no rotation, 3 compressors
 without t1, t2, t3 delays

Graph n.2

Example with $sEq=1$, $NC=3$ and the intervention of the times $t1$, $t2$, $t3$

Example of sideband insertion, no rotation, 3 compressors and the intervention of $t1$, $t2$, $t3$ delays

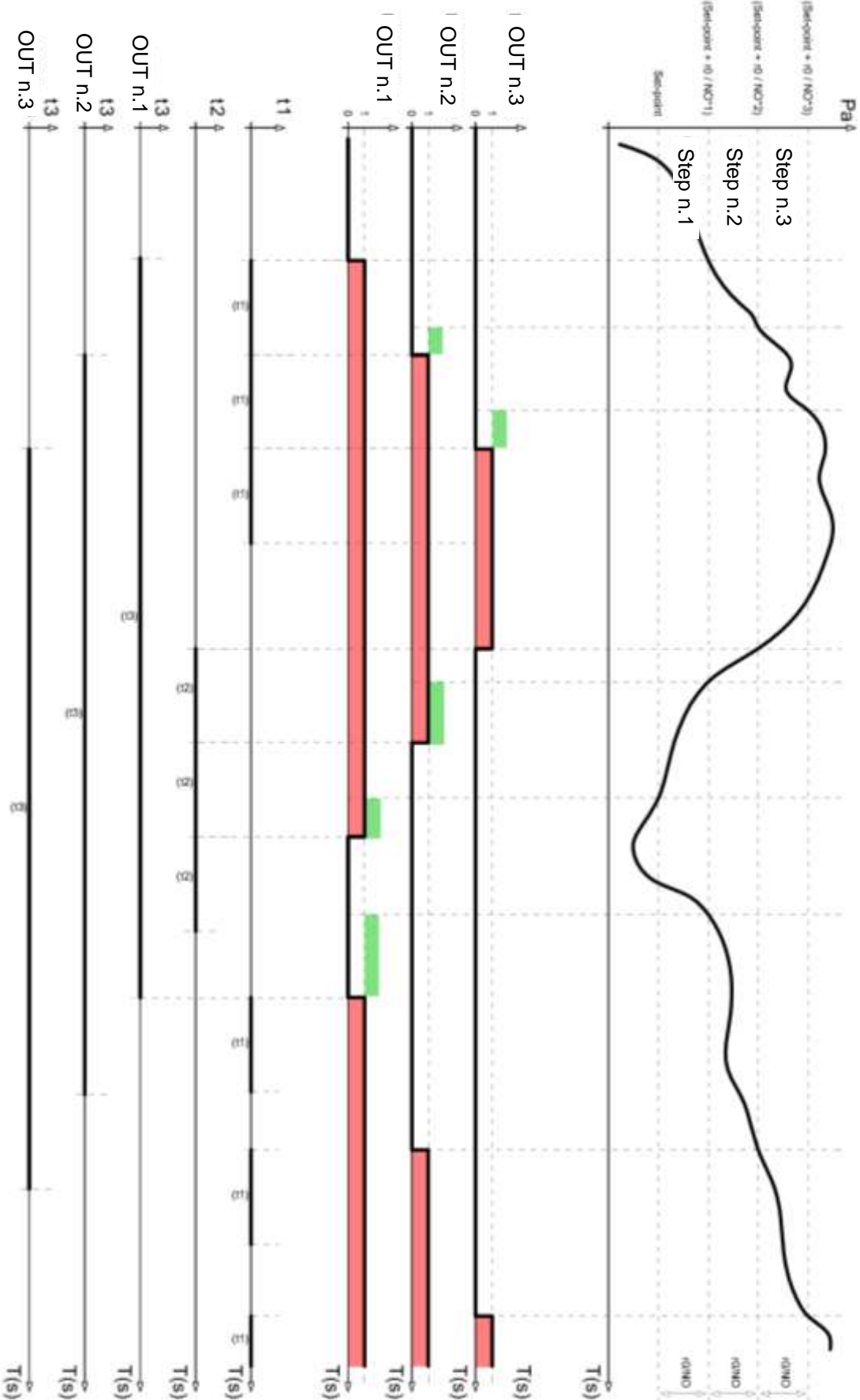

Graph n.3

Legend

Output state	Output state (on / off)
Pressure	pressure (Bar) for the activation of outputs
Set point	SET POINT (Bar) set by the operator.
r0	Differential SET. (First level parameter)
Step n.1,2,3	Insertion steps that are paired with the outputs based on the variable Seq
nU, nC	Nr. of outputs managed. (Third level parameter)

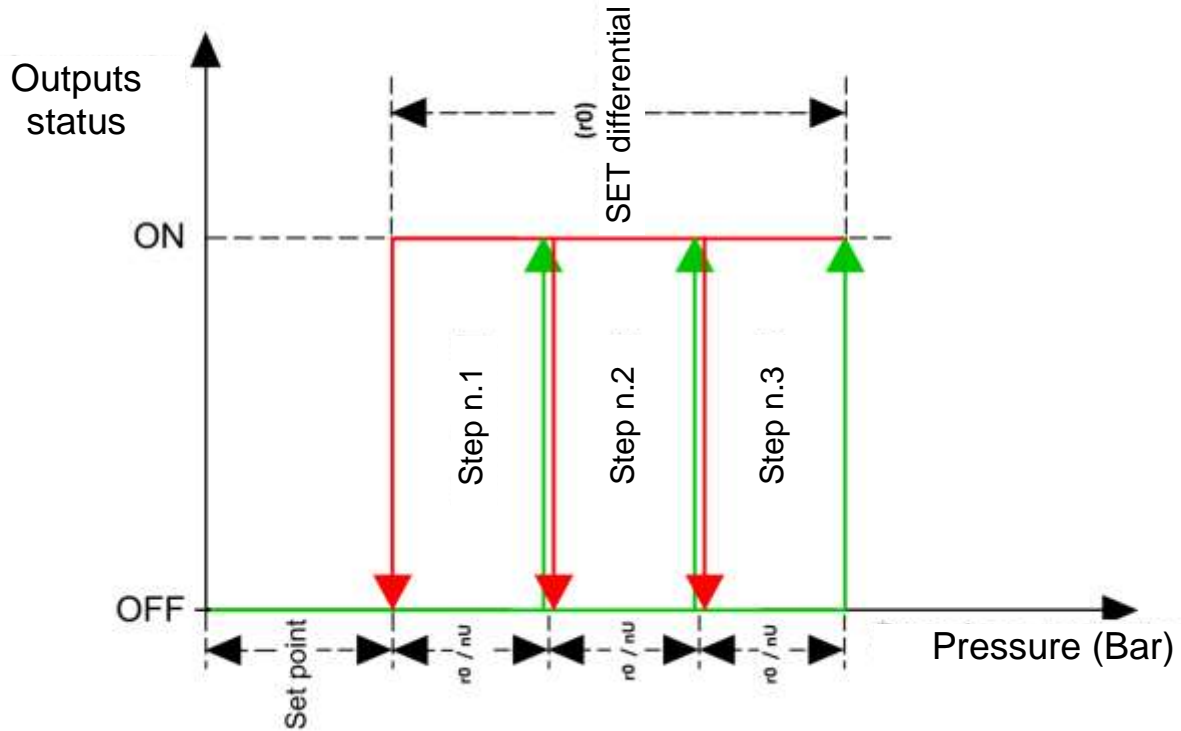

iEn = 1: compressor inverter management activated (nC > 0)

If iEn=1 and nC>0 compressor 1 is managed with the 0-10V output and a side-band control. The compressor 1 digital output is used to enable the inverter, the other digital outputs control the remaining compressors with a side-band control. The adjustment of the inverter is based on the operation shown in Graph no.4 as the pressure varies:

- When the first compressor step is activated, the inverter output is set to the minimum iMc value.
- Afterwards, the inverter output varies in proportion with the value read by the intake sensor (within a 0-10V range) and the other compressor outputs are controlled on a side-band basis;
- When there is a request to enable the second compressor stage and after the t1 time, the inverter output is gradually reduced down to the iMc value. Compressor output 2 is then activated and the inverter varies in proportion with the value read by the intake sensor;
- When a compressor step is disabled, the inverter output is gradually increased until it reaches the maximum value in the itS time. It then varies in proportion with the value read by the intake sensor.

CONTROL IN THE EVENT OF ALARMS

With the compressor output no.1 alarm input activated, the analogue output will be immediately brought to 0V and the digital output no.1 will be opened after (inverter-enabling is removed). The relative alarm (EC1) will also be shown on the display.

Graph n. 4 - Example inverter compressor operation. Seq=1, nC =3, and the intervention of times t1 e t2

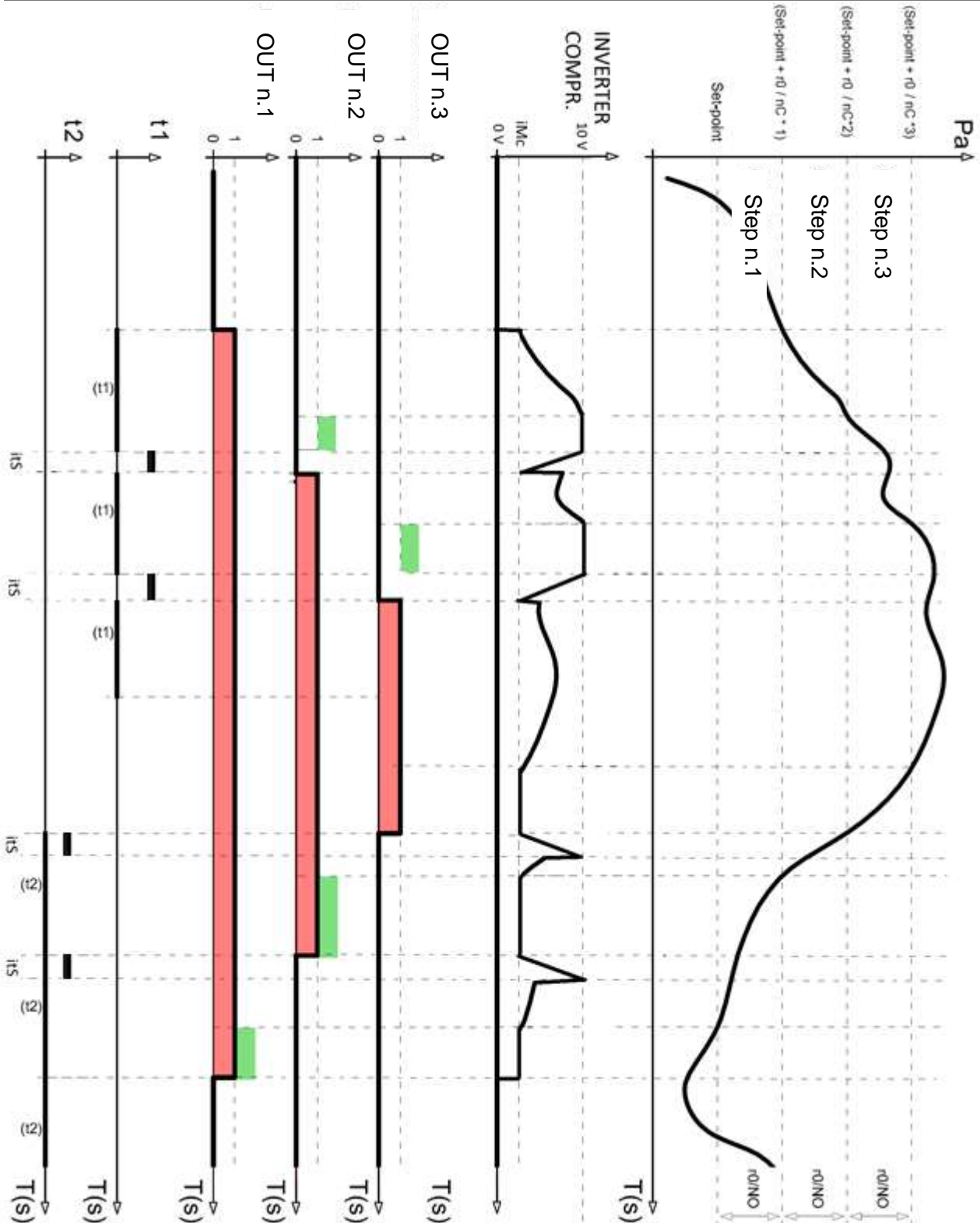

iEn = 1: fan inverter management enable (nU > 0)

If iEn=1 and nU>0 you will have the Condenser fan control with 0-10V analogue output and of sideband-type adjustment. Digital Output "Fan 1" represents "the condenser fans inverter activation"; the other fans digital outputs are disabled (all fans are controlled by the inverter). The adjustment follows the operation of graph no.5 with the increase of the output pressure and the decrease of graph no.6.

Output pressure INCREASE (Graph n.5):

The analogue output of the adjuster will be 0V for output pressure probe less or equal to point (B) representing the "SET point + iOv offset" value.

If the output pressure probe value is higher than point (B), you will have the analogue output at 10V for the maximum BOv time. BOv is the Fans Boost times for which the adjuster output is increased by 100% in order to help the start-up of the fans.

Between points (B) and (C), the analogue output will have a value proportional to the value of the output pressure probe starting from the minimum value of the parameter (iMv) up to the maximum value of 10V. With output pressure probe values equal or higher than point (C), you will have a 10V analogue output. Digital output no.1 represents "the condenser fans inverter activation" and is ON for pressure values higher than or equal to the set point and OFF for lower values.

Graph n.5

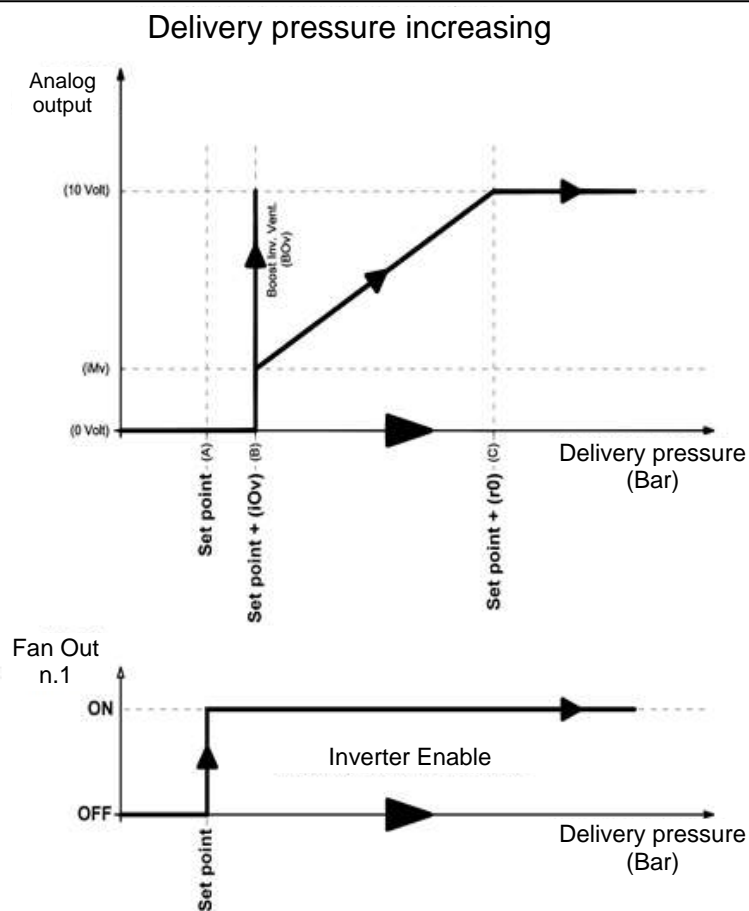

Output pressure DECREASING (Graph. n.6):

With output pressure probe values equal or higher than point (D), you will have a 10V analogue output.

Between points (D) and (E), the analogue output will have a value proportional to the value of the output pressure probe starting from the maximum value of 10V up to the minimum value of the (iMv) parameter. With values of the output pressure probe lower than point (E) and higher than point (F), you will have an analogue output equal to the minimum value of the (iMv) parameter. The analogue output of the adjuster will be 0V for output pressure probe less or equal to point (F) representing the "SET point" value. Digital output no.1 represents "the condenser fans inverter activation" and is ON for pressure values higher than or equal to the set point and OFF for lower values.

Graph n.6

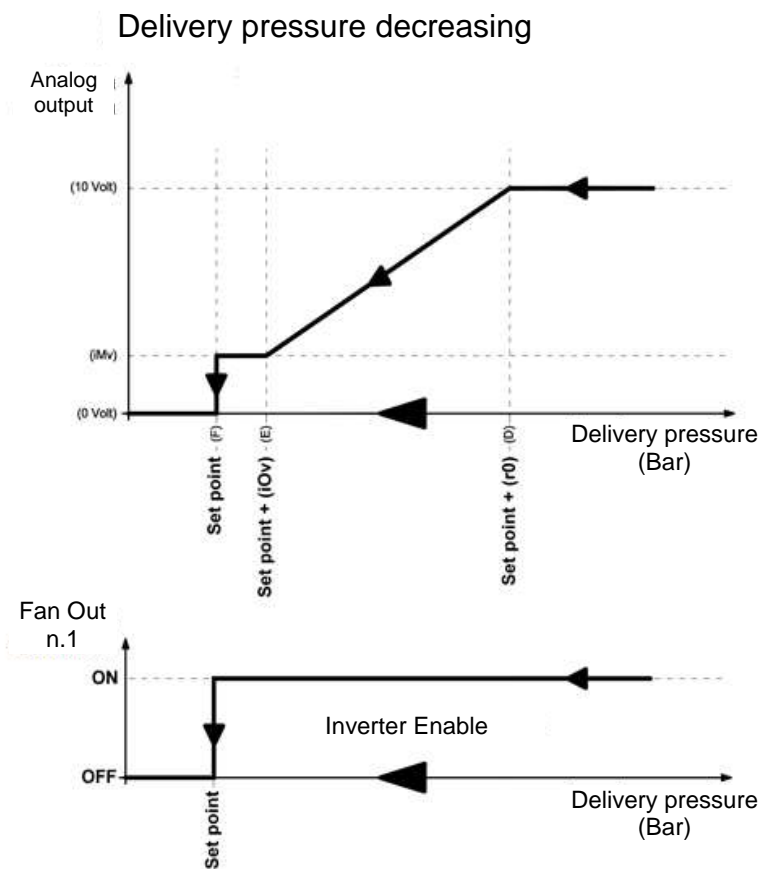
**CONTROL IN THE EVENT OF ALARMS**

With the fan output no.1 alarm input activated, the analogue output will be immediately brought to 0V and the digital output no.1 will be opened after (inverter-enabling is removed). The relative alarm (EU1) will also be shown on the display

With the NPC parameter = ± 1 and $nC > 0$ the operation of the compressors is selected and the digital outputs are controlled on a side-band basis and the CAPACITY CONTROL IS SET TO 50%. Then there are two possible variants based on the status of the SEq variable designed for the logical selection to activate the compressors.

- SEq parameter = 1 (without rotation)

Based on the value of the "SET COMPRESSORS", "r0" and "nC" parameters, the controller calculates the various areas where there is a request to enable and disable the compressor outputs (steps) by positioning the various switch-ons and switch-offs in the r0 differential range. Each step has a $(r0/nC)/2$ differential (where nC is the number of compressors).

Therefore, the number of steps is twice the number of the compressors (given the presence of the capacity control).

For instance, for compressor no.1 the enabling will occur at:

$$SET_{COMPR} + \left(\frac{(r0C)}{nC} \right) / 2 * 1 \quad (\text{constant 1 indicates step 1, } r0C = r0)$$

and the disabling will occur at:

$$SET_{COMPR} + \left(\frac{(r0C)}{nC} \right) / 2 * 0.$$

The enabling of the capacity control of compressor no.1 will occur at:

$$SET_{COMPR} + \left(\frac{(r0C)}{nC} \right) / 2 * 2$$

and the disabling will occur at:

$$SET_{COMPR} + \left(\frac{(r0C)}{nC} \right) / 2 * 1$$

(without considering the intervention of times t1 and t2).

In general, if SEq=1 the activation of the compressors and the capacity control follows this sequence: C1, PC1, C2, PC2. The deactivation is based on this sequence: PC2, C2, PC1, C1.

The number of compressors enabled depends on the deviation between the value measured by the adjustment pressure sensor (positioned at the intake) and the set intake Setpoint, as well as the t_1 e t_2 times. Namely, the “ t_1 ” time determines the minimum stay time of a step that has just been enabled, and the “ t_2 ” time the minimum stay time of a step that has just been disabled. These two times prevent considerable temporary pressure changes from causing the compressors to switch on and off.

Note: on the LED display, the capacity control is indicated by the fact that the icons “3” and “4” turn on. If a compressor or capacity control is waiting for the t_1 or t_2 time, the corresponding LEDs on the display start to flash.

- parameter SEq = 0 (with rotation)

If SEq=0 the compressors are activated based on their operating time. When there is a request to activate a step, a compressor with a shorter operating time is activated, provided it is not in stand-by and that there is no alarm associated with it. Upon a subsequent request to enable a step, the capacity control of the last compressor enabled will be activated. The compressor and relative capacity control are always activated and deactivated in pairs: if the step is disabled, first the capacity control will be disabled and then the relative compressor.

Note: if the Compressor inverters management is active (parameter iEn=1), the capacity control cannot be used.

For further information on how the Capacity Control is managed, see Graph 7.

Graph n.7

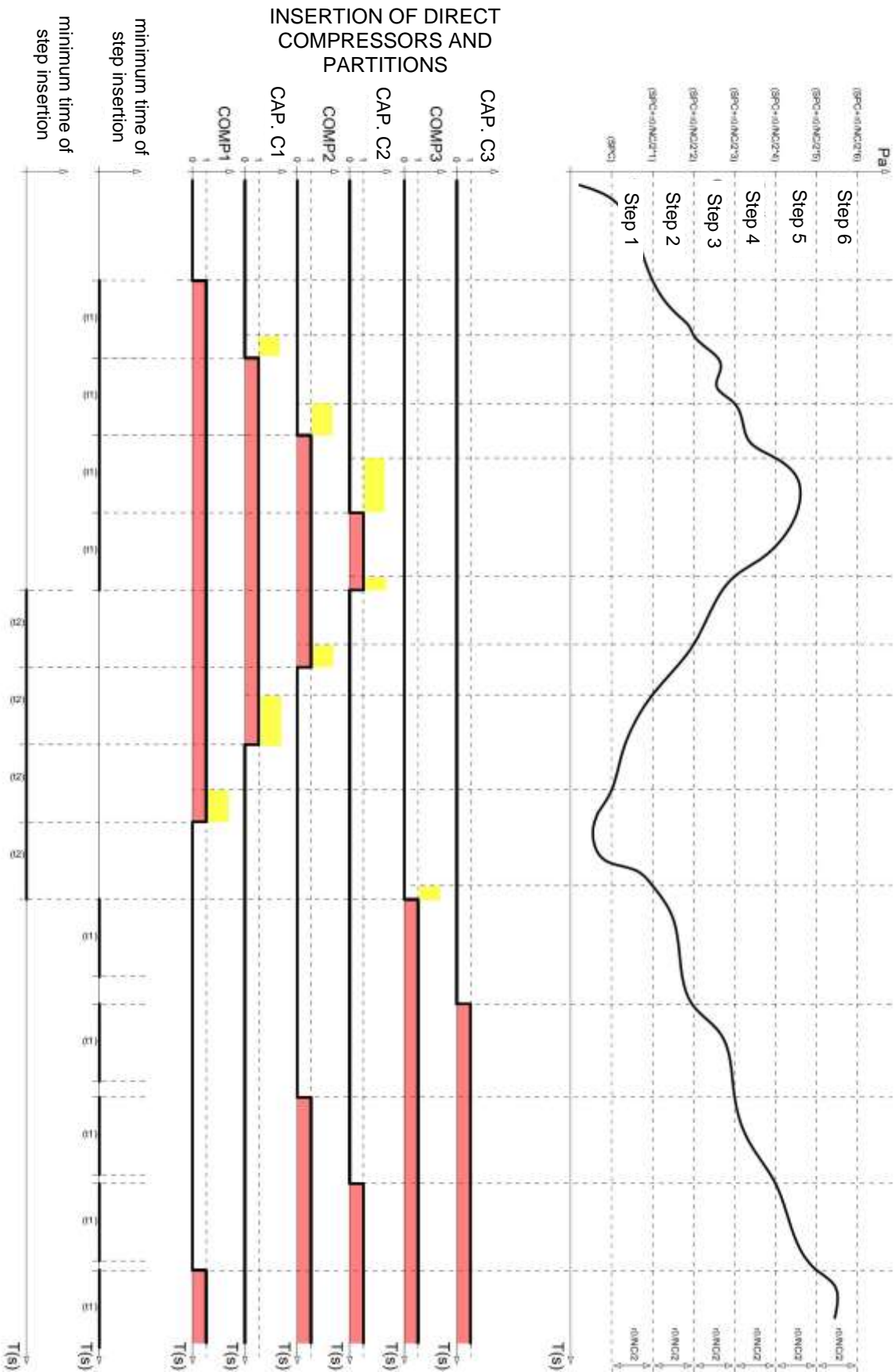

5.18

PASSWORD FUNCTION

The password function is enabled by setting a value other than 0 in the PA parameter. See parameter P1 for the various levels of protection.

Protection is enabled automatically when the keypad is not used for 30 seconds.

The digits 000 appear on the display. Use the up/down arrow keys to edit the number and press the SET key to confirm.

The 000 password window disappears if the keypad is not used for 30 seconds.

If you forget the password, use the universal number 100.

5.19

TEMPERATURE TABLE FOR REFRIGERANT FLUIDS

The following table shows the limits for the converted temperature based on kind of gas set (Parameter Fty).

Parameter Fty	Code	Temperature range	Parameter Fty	Code	Temperature range
0	R404	-50 ÷ 70 °C	11	R449A	-50 ÷ 70 °C
1	R134A	-50 ÷ 70 °C	12	R290	-50 ÷ 70 °C
2	R22	-50 ÷ 70 °C	13	R32	-50 ÷ 70 °C
3	R407A	-50 ÷ 70 °C	14	R448A	-50 ÷ 70 °C
4	R407F	-50 ÷ 70 °C	15	R452A	-50 ÷ 70 °C
5	R407H	-50 ÷ 70 °C	16	R600	-20 ÷ 70 °C
6	R410A	-50 ÷ 70 °C	17	R600A	-30 ÷ 70 °C
7	R450A	-40 ÷ 70 °C	18	R1270	-50 ÷ 70 °C
8	R507	-50 ÷ 70 °C	19	R1234ZE	-30 ÷ 70 °C
9	R513A	-45 ÷ 70 °C	20	R23	-50 ÷ 25 °C
10	R744 (CO2)	-50 ÷ 40 °C	21	R717 (NH3)	-50 ÷ 70 °C

CHAPTER 6: OPTIONS

TELENET MONITORING/SUPERVISION SYSTEM

6.1

In order to connect the board to the **TeleNET** network, follow the diagram below. Configure the instrument with reference to the **TeleNET** manual.

IMPORTANT: During configuration of the “Module”, select "Instrument Vision SC600".

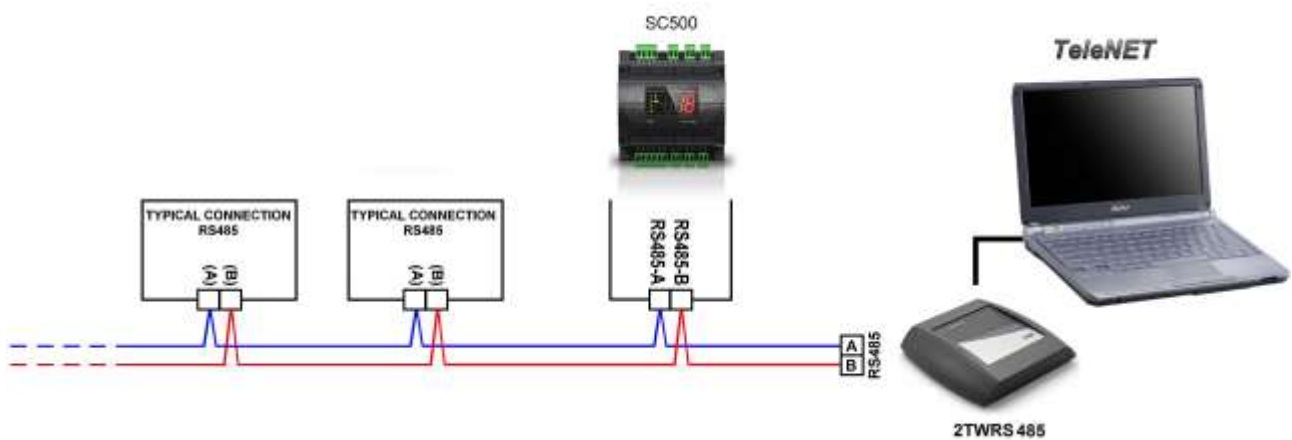

Note:

The instrument DIN NANO SC500 if questioned as “TWMP instrument” answers with the low pressure probe measurement (intake) to the address set in the parameter Ad. The variable matching between VISION SC600 and NANOSC 500 on Telenet is the following:

VISION SC600 (Telenet)	DIN NANO SC500 COMPRESSORS (nC>0)	DIN NANO SC 500 COND. FANS (nU>0)
Setpoint intake	Setpoint	---
Setpoint delivery	---	Setpoint
r0C	r0	---
r0U	---	r0
A1C	A1	---
A2C	A2	---
A1U	---	A1
A2U	---	A2
LSC	LSE	---
HSC	HSE	---
LSU	---	LSE
HSU	---	HSE

CHAPTER 7: DIAGNOSTICS

7.1

DIAGNOSTICS

In case of anomalies, the **DIN NANO SC500** controller warns the operator using alarm codes shown by the display and an acoustic signal emitted by a buzzer inside the Operational console.

When there is an alarm, the  icon starts flashing on the display, the alarm relay is activated (if enabled), as well as the internal buzzer and one of the alarm codes is displayed (the code is alternated with the page normally displayed).

The internal buzzer can be silenced at any time by pressing the "Sound off" key. Press the SET key to reset the audio signal. If an alarm has been silenced and another kind of alarm is tripped (a different one from the one currently reported), the audio signal goes off again and the error code will be shown based on the display priority.

There can be two kinds of alarm based on how serious they are:

- Automatic reset (the alarm is automatically reset when the problem is cleared);
- Manual reset from the keyboard (the alarm is reset once it has been acquired by the operator via the "Sound off" key).

When the alarm is cleared, the icon stops flashing and becomes steady to tell the operator that an alarm with an automatic reset was tripped and is no longer activated. The display goes back to showing the normal page and the alarm code is no longer shown. When the "Sound off" key is pressed, the steady  icon turns off. The alarm code with the top priority tripped is saved and can be displayed (read-only) in the first-level ALL variable.

The view of this variable at the first commissioning (with empty memory) will display ---.

The alarms are displayed in the following order of priority: E0, E1, EH, EL, EHc, ELc, EHu, ELu, E8, EF, EC1...EC5, EU1....EU5, EC, Eu, EO5, E7, EP, En, E6.

ALARM CODE TABLE:

COD.	POSSIBLE CAUSE / DESCRIPTION	ACTION TO BE TAKEN	RESET
OFF	Remote stand-by active (digital input)	Plant stops and display flashes "OFF" and pressure value.	automatic
InS	Remote stand-by active (digital input)	Plant stops and display flashes "InS" and pressure value.	automatic
E0	EEPROM ALARM An error was found in the EEPROM memory. (The outputs are all disabled apart from the alarm outputs)	<ul style="list-style-type: none"> • Switch the appliance off and back on • If the problem persists, replace the Control Circuit Board 	manual Requires shut-down
E1	Operation anomalies of the pressure probe (outputs disabled)	<ul style="list-style-type: none"> • Check the probe status 	automatic
EPH	Pressostat alarm - Maximum delivery pressure (digital input) (compressor outputs are disabled, fan outputs remain unchanged)	<ul style="list-style-type: none"> • Check the refrigerant circuit • If the problem persists contact the technical assistance service 	automatic
EPL	Pressostat alarm - Minimum intake pressure (digital input) (all outputs disabled)	<ul style="list-style-type: none"> • Check the refrigerant circuit • If the problem persists contact the technical assistance service 	automatic
EHc	Maximum intake pressure alarm (compressors outputs remain unchanged)	<ul style="list-style-type: none"> • Check the refrigerant circuit • If the problem persists contact the technical assistance service 	automatic
ELc	Minimum intake pressure alarm (compressors outputs disabled)	<ul style="list-style-type: none"> • Check the refrigerant circuit • If the problem persists contact the technical assistance service 	automatic
EHu	Maximum delivery pressure alarm (fans outputs remain unchanged)	<ul style="list-style-type: none"> • Check the refrigerant circuit • If the problem persists contact the technical assistance service 	automatic
ELu	Minimum delivery pressure alarm (fans outputs disabled)	<ul style="list-style-type: none"> • Check the refrigerant circuit • If the problem persists contact the technical assistance service 	automatic
E7	Central pre-alarm in manual mode. This alarm does not change the status of the outputs.	<ul style="list-style-type: none"> • Check the configuration of the parameters. • Check the status of the inlet of the "central alarm in manual mode". 	automatic
E8	Central alarm in manual mode. It is triggered after 5 interventions in the (Nip) time of its digital input ("central alarm in manual mode"). (The outputs are all disabled apart from the alarm outputs)	<ul style="list-style-type: none"> • Check the configuration of the parameters. • Check the status of the inlet of the "central alarm in manual mode". 	manual, putting on stand-by
EC1 EC2 EC3 EC4 EC5	Protection of one or more compressor outputs (e.g. Thermal protection or max. pressure switch.) (The output of the relative COMPRESSOR is deactivated)	<ul style="list-style-type: none"> • Check the status of the compressor(s). • Check the absorption of the compressor(s). • Check the status of the "outlet no.# alarm" inlet. 	automatic

Eu1 Eu2 Eu3 Eu4 Eu5	Protection of one or more condenser fans (e.g. Thermal protection or max. pressure switch.) (The output of the relative FAN is deactivated)	<ul style="list-style-type: none"> • Check the status of the fan(s). • Check the absorption of the fan(s). • Check the status of the "outlet no.# alarm" inlet. 	automatic
EC	Display of the alarm in read-only of one or more compressor outputs (no output is deactivated)	<ul style="list-style-type: none"> • Check the status of the compressor(s). • Check the absorption of the compressor(s). • Check the status of the "only-read alarm".. 	automatic
Eu	Display of the alarm in read-only of one or more fan outputs (no output is deactivated)	<ul style="list-style-type: none"> • Check the status of the compressor(s). • Check the absorption of the compressor(s). • Check the status of the "only-read alarm". 	automatic
EO5	One or more digital output have reached a number of operating hours beyond which maintenance is required. This alarm does not change the status of the outputs.	Perform maintenance and reset the hour meter of its digital output	manual
EP	Freon/oil level pre-alarm This alarm indicates that the "freon level alarm" remained high for a time lower than "rLo". This alarm does not change the status of the outputs.	<ul style="list-style-type: none"> • Check the device connected to the System that signalled the alarm condition • Check the status of the "freon/oil level alarm" inlet. 	automatic
EF	Freon/oil level alarm This alarm indicates that the "freon level alarm" remained high for a time longer than "rLo". This alarm deactivates all outputs.	<ul style="list-style-type: none"> • Check the device connected to the System that signalled the alarm condition • Check the status of the "freon/oil level alarm" inlet. 	automatic
E6	Discharged battery alarm; control function for at least another 20 days, then if there is not power to the time setting will be lost.	<ul style="list-style-type: none"> • Replace the Console lithium battery (CR2032 type) 	manual
En	Communication error between the ECHO display and the Master	<ul style="list-style-type: none"> • Switch the appliance off and back on. • If the problem persists contact the technical assistance service. 	automatic

The NANO DIN SC500 can log up to 40 alarm events. To display the codes of the logged alarms, press UP key for at least 3 seconds.

The display will show the most recent alarm code. Repeatedly pressing the SET button the display shows:

- Hr: alarm hour.
- Min: alarm minute.
- day: alarm day.
- mon: alarm month.
- Yr: alarm year

Use the UP and DOWN keys to scroll through the recordings, starting from the most recent. To clear the records, press SET and Stand_by simultaneously for 10 seconds while it is being displayed; at the end of this time the instrument will beep. If there are no alarms in memory, the system does not enter in alarm menu.

To exit the page displayed, press the UP and DOWN keys together for at least 3 seconds. The instrument exits automatically if no keys are pressed for 30 seconds.

When the instrument is turned on, the "On" code is logged with the relative time of the event.

ATTACHMENTS

A.1

EU DECLARATION OF CONFORMITY

LA PRESENTE DICHIARAZIONE DI CONFORMITA' E' RILASCIATA SOTTO LA RESPONSABILITA' ESCLUSIVA DEL FABBRICANTE:
THIS DECLARATION OF CONFORMITY IS ISSUED UNDER THE EXCLUSIVE RESPONSIBILITY OF THE MANUFACTURER:



PEGO S.r.l. Via Piacentina 6/b, 45030 Occhiobello (RO) – Italy –

DENOMINAZIONE DEL PRODOTTO IN OGGETTO / DENOMINATION OF THE PRODUCT IN OBJECT

MOD.: NANO DIN SC500

IL PRODOTTO DI CUI SOPRA E' CONFORME ALLA PERTINENTE NORMATIVA DI ARMONIZZAZIONE DELL'UNIONE EUROPEA:
THE PRODUCT IS IN CONFORMITY WITH THE RELEVANT EUROPEAN HARMONIZATION LEGISLATION:

Direttiva Bassa Tensione (LVD):	2014/35/UE
Low voltage directive (LVD):	2014/35/EU
Direttiva EMC:	2014/30/UE
Electromagnetic compatibility (EMC):	2014/30/EU

LA CONFORMITA' PRESCRITTA DALLA DIRETTIVA E' GARANTITA DALL'ADEMPIMENTO A TUTTI GLI EFFETTI DELLE SEGUENTI NORME:
THE CONFORMITY REQUIRED BY THE DIRECTIVE IS GUARANTEED BY THE FULFILLMENT TO THE FOLLOWING STANDARDS:

Norme armonizzate:	EN 61010-1:2010, EN 61326-1:2013
European standards:	EN 61010-1:2010, EN 61326-1:2013

IL PRODOTTO E' COSTITUITO PER ESSERE INCORPORATO IN UNA MACCHINA O PER ESSERE ASSEMBLATO CON ALTRI MACCHINARI PER COSTITUIRE UNA MACCHINA CONSIDERATE DALLA DIRETTIVA: 2006/42/CE "Direttiva Macchine".
THE PRODUCT HAS BEEN MANUFACTURED TO BE INCLUDED IN A MACHINE OR TO BE ASSEMBLED TOGETHER WITH OTHER MACHINERY TO COMPLETE A MACHINE ACCORDING TO DIRECTIVE: EC/2006/42 "Machinery Directive".

Firmato per nome e per conto di:
Signed for and on behalf of:

Pego S.r.l.
Lisa Zampini
Procuratore Generale

Luogo e Data del rilascio:
Place and Date of Release:

Occhiobello (RO), 08/01/2018

CONNECTION LAYOUT

A.2

Power supply

PIN	DESCRIPTION
1 – 2	N – L Power supply 230Vac ±10% 50/60Hz Consumption: 5 VA max.

TeleNET

PIN	DESCRIPTION
18	line A or terminal 3 of TWRS485
19	line B or terminal 4 of TWRS485

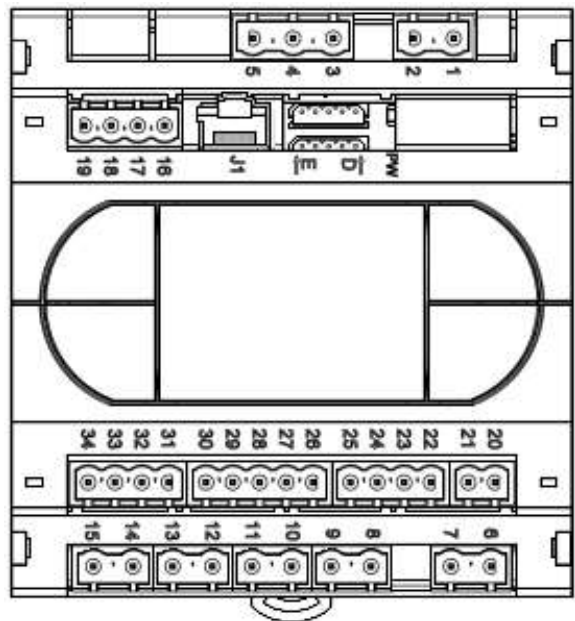

Digital outputs

PIN TERMINAL	RELAY OUTPUTS FEATURES (Voltage free contacts)	DESCRIPTION (see cap. 5.15)
6 – 7 (DO1)	relay 8A AC1 10 (10) A 250V~ (AC3)	Out 1: Compr. / Fan
8 – 9 (DO2)	relay 16A AC1 10 (4) A 250V~ (AC3)	Out 2: Compr. / Partition / Fan
10 – 11 (DO3)	relay 16A AC1 10 (4) A 250V~ (AC3)	Out 3: Compr. / Partition / Fan
12 – 13 (DO4)	relay 16A AC1 10 (4) A 250V~ (AC3)	Out 4: Compr. / Partition / Fan
14 – 15 (DO5)	relay 8A AC1 10 (4) A 250V~ (AC3)	Out 5: Compr. / Partition / alarm

Analog input

PIN TERMINAL	PROBE TYPE	DESCRIPTION
28 (In) – 30 (V+)	4–20 mA	Pressure probe (J1 closed)

Analog output

PIN TERMINAL	DESCRIPTION
20 (-) 21 (+)	0-10V inverter Output

Digital inputs

(use free voltage contacts)

PIN TERMINAL	DESCRIPTION
25 – 24	Digital input DI1
25 – 23	Digital input DI2
25 – 22	Digital input DI3
26 - 27	Digital input DI4
34 – 31	Digital input DI5
34 – 32	Digital input DI6
34 - 33	Digital input DI7



PEGO s.r.l.
Via Piacentina, 6/b 45030 Occhiobello ROVIGO – ITALY
Tel. +39 0425 762906 Fax +39 0425 762905
e.mail: info@pego.it – www.pego.it

AFTER-SALES ASSISTANCE CENTRE
Tel. +39 0425 762906 e.mail: tecnico@pego.it

Distributor: