

VISION 2PLT

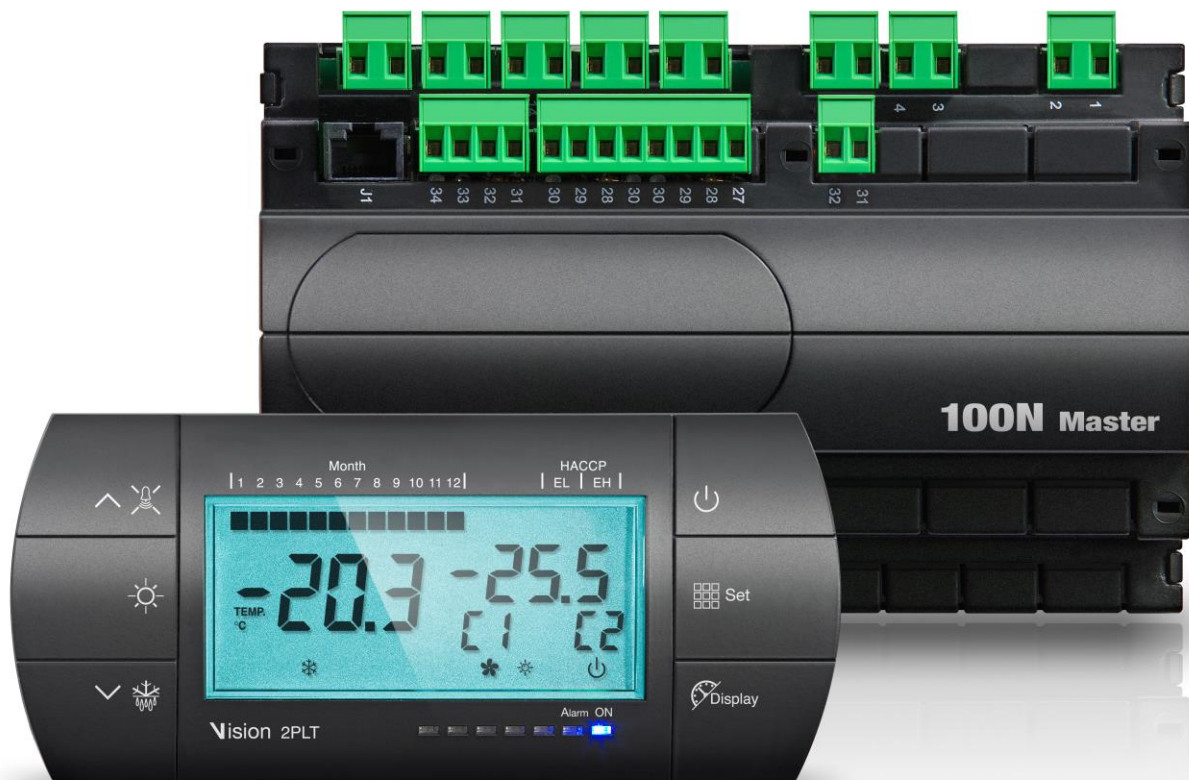

Use and maintenance manual

ENGLISH

READ AND KEEP

CONTENTS

INTRODUCTION

CHAP. 1

Pag. 4	1.1	General
Pag. 5	1.2	Product ID codes
Pag. 5	1.3	Overall dimensions
Pag. 5	1.4	Identification data

INSTALLATION

CHAP. 2

Pag. 6	2.1	Important information for installer
Pag. 6	2.2	Standard assembly and use kit
Pag. 7	2.3	Installation

FUNCTIONS

CHAP. 3

Pag. 8	3.1	Functions managed by the VISION 2PLT
--------	-----	--------------------------------------

TECHNICAL CHARACTERISTIC

CHAP. 4

Pag. 9	4.1.	Technical characteristics
Pag. 10	4.2	Warranty terms

DATA PROGRAMMING

CHAP. 5

Pag. 11	5.1	Panel layout
Pag. 11	5.2	Keypad functions
Pag. 12	5.3	LCD display
Pag. 13	5.4	General
Pag. 13	5.5	Key to symbols
Pag. 14	5.6	Setting and displaying the set-points
Pag. 14	5.7	Probes value display
Pag. 14	5.8	Level 1 programming
Pag. 15	5.9	List of Level 1 variables
Pag. 16	5.10	Level 2 programming
Pag. 17	5.11	List of Level 2 variables
Pag. 20	5.12	Switching on the VISION 2PLT electronic controller
Pag. 20	5.13	Compressor activation/deactivation conditions
Pag. 20	5.14	Configurations
Pag. 20	5.15	Single set-point with double system
Pag. 20	5.16	Double set point
Pag. 21	5.17	Defrost management
Pag. 21	5.18	Heater defrost, with temperature control
Pag. 22	5.19	Hot gas defrosting
Pag. 22	5.20	Operating mode

OPTIONS

CHAP. 6

Pag. 23	6.1	TeleNET monitoring / supervision system
---------	-----	---

DIAGNOSTICS

CHAP. 7

Pag. 24	7.1	Diagnostics
---------	-----	-------------

ATTACHMENTS

Pag. 26	A.1	EU declaration of conformity
Pag. 27	A.2	100N MASTER3 connection layout

CHAPTER 1: INTRODUCTION

1.1

GENERAL

The electronic controllers of the **VISION** series have been designed to control static or ventilated cold rooms.

The **VISION 2 PLT** electronic panel allows the user to control all the components on a refrigeration unit equipped with a double system. The panel allows the user to control the essential components of a refrigeration system with up to two compressors, a double evaporator (fans and defrosting elements) and a cold room light.

The double evaporator is controlled separately with a double defrosting sensor and it's possible to set different start times for defrost the evaporators. It's possible to insert a secondary environment probe to ensure the proper functioning of the system in case of failure of the main room sensor.

APPLICATIONS:

- Control static or ventilated cold rooms with double system.

MAIN FEATURES:

- Backlit LCD display.
- Clock and date.
- Temperature with decimal point.
- Password lock keys.
- Management of two separate evaporators (start cyclic or time set).
- Double room sensor management for operation in critical situations.
- Room light control.
- Management of heater defrost, with temperature control.
- Management of hot gas defrost (with or without basin resistance).
- Management of compressor rotation (for a similar aging).

PRODUCT ID CODES

1.2

VISION 2PLT

Controller for cold storage cell with double system.

OVERALL DIMENSIONS

1.3

Dimensions in mm

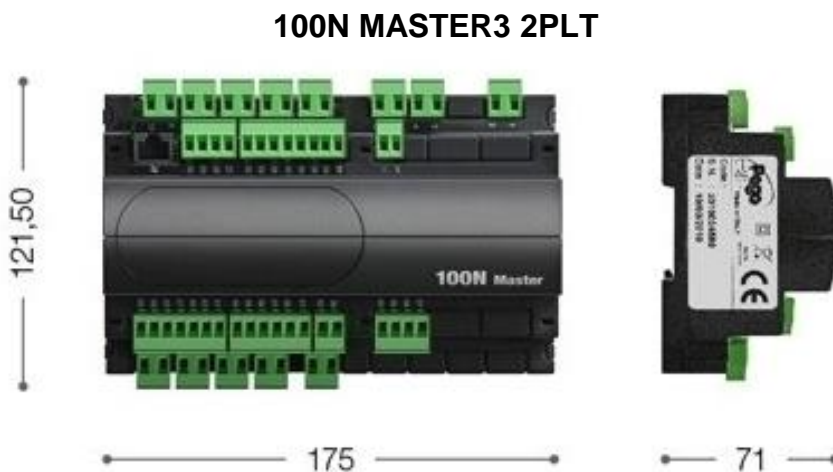

DENTIFICATION DATA

1.4

The unit described in this manual has, on its side, an ID plate showing all the relevant identification data:

- Name of Manufacturer
- Code and model of the unit
- Serial number
- Date of production
- Power supply voltage



CHAPTER 2: INSTALLATION

2.1

IMPORTANT INFORMATION FOR THE INSTALLER

1. Install the device in places where the protection rating is observed and try not to damage the box when drilling holes for wire/pipe seats.
2. Do not use multi-polar cables in which there are wires connected to inductive/power loads or signalling wires (e.g. probes/sensors and digital inputs).
3. Do not fit power supply wiring and signal wiring (probes/sensors and digital inputs) in the same raceways or ducts.
4. Minimise the length of connector wires so that wiring does not twist into a spiral shape as this could have negative effects on the electronics.
5. Fit a general protection fuse upstream from the electronic controller.
6. All wiring must be of a cross-section suitable for relevant power levels.
7. When it is necessary to make a probe/sensor extension, the wires must be of the correct cross-section, which in any case must be at least 1mm². The extension or shortening of the probes could alter the factory calibration, then proceed to checkout and calibration by means of an external thermometer.

2.2

STANDARD ASSEMBLY AND USE KIT

The **VISION 2PLT** electronic controller is supplied with the following assembly and utilisation items:

- N° 4 NTC temperature probes;
- N° 1 telephone plug cable (**KCVTELPL8/5**);
- N° 1 user's manual;
- N° 1 consolle VISION 2PLT (**200VISION2PLT**);
- N° 1 100N MASTER3 (**200100NMSTH3**);

Fig. 1: Position the **100N MASTER3** module on the DIN guide and close the 2 lower hooks to lock it on the same.

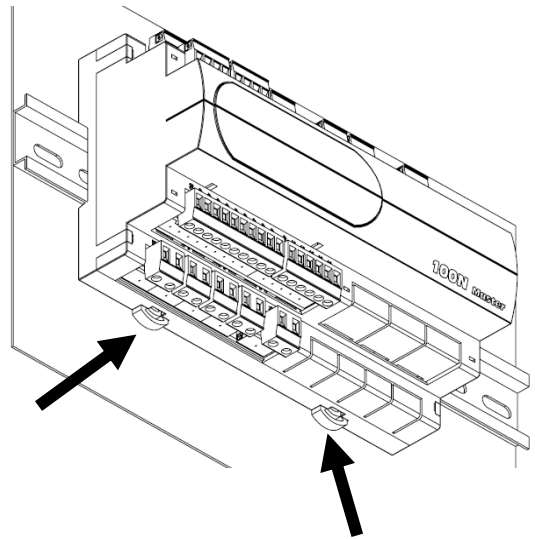

Fig. 2: Fix the **VISION 2PLT** console using the two screws to be inserted in the slots underneath the keys frame.

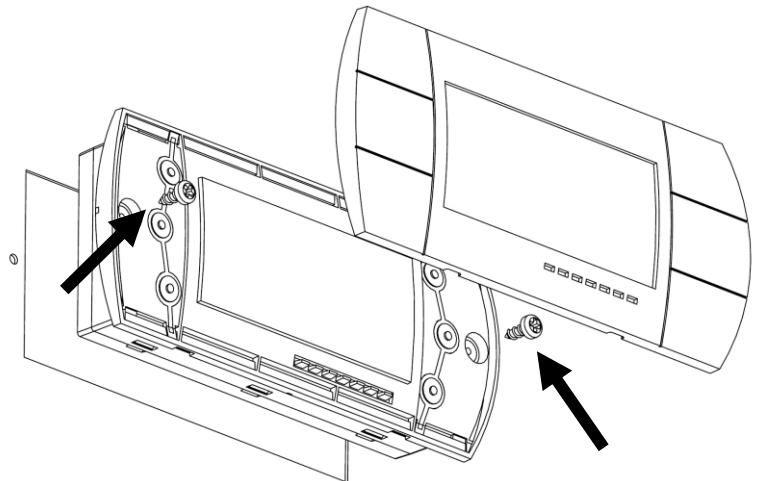
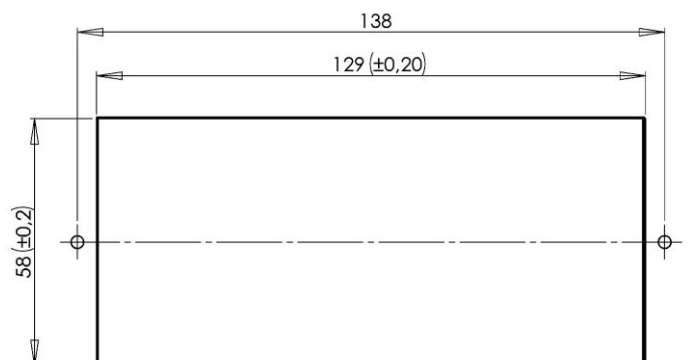

Fig. 3: **VISION 2PLT** console perforation template.



CHAPTER 3: FUNCTIONS

3.1

FUNCTIONS CONTROLLED BY THE VISION 2PLT

- Display and adjustment of room temperature.
- Display of evaporator 1 and evaporator 2 temperature.
- Display of ambient 1 and ambient 2 temperature.
- System control activation/deactivation.
- Operation with single set-point and control of two motor condensing units with delays between the two parameter-set starts.
- Compressor rotation (to make wear uniform).
- Operation with double set point for gradual application of refrigerating power.
- System warnings (ambient $\frac{1}{2}$ temperature sensor error, min-max temperature alarms, compressor 1 and compressor 2 safety devices, man in room alarm, different probe values alarm).
- Evaporator 1 and evaporator 2 fan control.
- Automatic/manual defrost control (static, with elements, with elements with temperature control, cycle inversion and cycle inversion with basin).
- Clock for real time clock defrosting of the two evaporators simultaneously or separately (even where defrosting cycle is set simultaneously the end-of-defrost temperature and control of fan start delay on the two evaporators are independent).
- Room light can be switched on with on-panel key or door switch.
- Alarm relay.
- Management twin probe security environment. If the room sensor 1 is faulty alarm is signaled and the reference sensor control changes automatically.
- Functionality password to control access to different levels of programming.
- Operation in emergency mode if all ambient probes are faulty.
- Air recirculation management.

CHAPTER 4: TECHNICAL CHARACTERISTICS

TECHNICAL CHARACTERISTICS

4.1

Power supply			
Voltage	230 V~ ± 10% 50/60Hz		
Max. power absorption (only electronic control)	~ 8 VA		
Climatic conditions			
Working temperature	-5 ÷ +50 °C		
Storage temperature	-10 ÷ +70 °C		
Relative humidity	Below 90% Hr		
General characteristics			
Type of sensors that can be connected	NTC 10K 1%		
Resolution	0,1 °C		
Sensor read precision	± 0,5 °C		
Read range	-45 ÷ +99 °C		
Output characteristics			
Description	Installed relay	Output board characteristics	Note
Cold (output 3-4)	(Relè 30A AC1)	30A 240V~ (AC1) 10A 240V~ (AC3) (2HP) (100000 cycles)	All outputs are free-voltage contacts
n°9 outputs from 5 to 26 (see connection diagram)	(Relè 16A AC1)	16A 240V~ (AC1) 3A 240V~ (AC3)	
Dimensional characteristics			
Dimensions 100N MASTER 3	121,50mm x 71mm x 175mm (HxPxL)		
Dimensions VISION 2PLT (built-in)	70mm x 32mm x 158mm (HxPxL)		
Insulation / mechanical characteristics			
Display protection rating	IP65		
Box material	ABS self-extinguishing		

4.2

WARRANTY CONDITIONS

The **VISION 2PLT** series electronic controls are covered by a 24-months warranty against all manufacturing defects as from the date indicated on the product ID code.

In case of defect the product must be appropriately packaged and sent to our production plant or to any authorized Service Center with the prior request of the Return Authorization Number.

Customers are entitled to have defective products repaired, spare parts and labour included. The costs and the risks of transport are at the total charge of the Customer. Any warranty action does not extend or renew its expiration.

The Warranty does not cover:

- Damages resulting from tampering, impact or improper installation of the product and its accessories.
- Installation, use or maintenance that does not comply with the instructions provided with the product.
- Repair work carried out by unauthorized personnel.
- Damage due to natural phenomena such as lightning, natural disasters, etc...

In all these cases the costs for repair will be charged to the customer.

The intervention service in warranty can be refused when the equipment is modified or transformed.

Under no circumstances **Pego S.r.l.** will be liable for any loss of data and information, costs of goods or substitute services, damage to property, people or animals, loss of sales or earnings, business interruption, any direct, indirect, incidental, consequential, damaging, punitive, special or consequential damages, in any way whatsoever caused, whether they are contractual, extra contractual or due to negligence or other liability arising from the use of the product or its installation.

Malfunction caused by tampering, bumps, inadequate installation automatically declines the warranty. It is compulsory to observe all the instructions in this manual and the operating conditions of the product.

Pego S.r.l. disclaims any liability for possible inaccuracies contained in this manual if due to errors in printing or transcription.

Pego S.r.l. reserves the right to make changes to its products which it deems necessary or useful without affecting its essential characteristics.

Each new release of the Pego product user manual replaces all the previous ones.

As far as not expressly indicated, is applicable the Law and in particular the art. 1512 C.C. (Italian Civil Code).

For any controversy is elected and recognized by the parties the jurisdiction of the Court of Rovigo.

CHAPTER 5: DATA PROGRAMMING

PANEL LAYOUT

5.1



KEYPAD FUNCTIONS

5.2

- 1



PROBE VALUES / TIME DISPLAY (if pressed for more than 3 seconds the current time is displayed for a few seconds)
- 2



**UP
MUTE ALARM / DISPLAY LAST ALARM** (if long pressed)
- 3



STAND BY (ON/OFF)
- 4



SET key, room temperature
 (with double set point both are shown alternately)

5  DOWN / ENTER MANUAL DEFROST MENU (if long pressed)

6  ROOM LIGHT

5.3

DISPLAY LCD

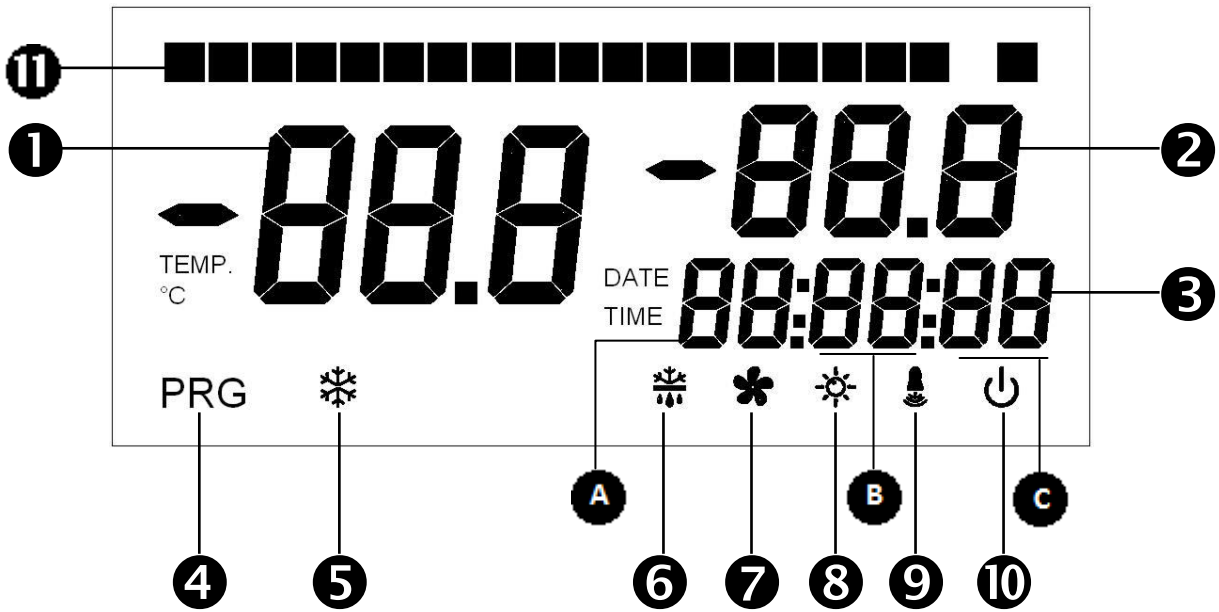







1. Ambient temperature / parameters

2. Value of ambient probe / defrost 1 probe / defrost 2 probe / current day / parameter value / alarm code

System status / time / time parameter values

3.

Zone	Written displayed	Fixed state	Flashing state
C	C1	Compressor 1 active	Compressor 1 waiting for C1 delay, will be the next to ignite (progr. 2°lev.)
B	C2	Compressor 2 active	Compressor 2 waiting for C1 delay, will be the next to ignite (progr. 2°lev.)
C	d1	Evaporator 1 defrosting	Evaporator 1 in dripping
B	d2	Evaporator 2 defrosting	Evaporator 2 in dripping
A B C	Current time		Hour : minute : second
A B C	Defrost time		Hour: minute : second
A B C	dEFr	Defrost menu active	
A	Regulation probe index (displayed in zone 1)	1 = ambient probe 1 2 = ambient probe 2 A = mean of ambient probes	

4.	PRG	Programming (control is in programming mode)
5.		Cold (compressor call indicator, if flashing a compressor 1 is waiting C1 delay)
6.		Defrost (if flashing an evaporator is in drip mode)
7.		Fans (flashing during fan stop – parameter F5)
8.		Light
9.		Alarm
10.		Stand-by (flashing in stand-by. Outputs deactivated)
11.		Current month



GENERAL**5.4**

To enhance safety and simplify the operator's work, the **VISION 2PLT system** has two programming levels; the first level (Level 1) is used to configure the frequently-modified **SET-POINT** parameters. The second programming level (Level 2) is for general parameter programming of the various controller work modes.

It is not possible to access Level 2 programming directly from Level 1: you must exit the programming mode first.

KEY TO SYMBOLS**5.5**

For purposes of practicality the following symbols are used:

- (▲) the UP key  is used to increase values, mute the buzzer and display last temperature alarm;
- (▼) the DOWN key  is used to decrease values and force defrosting.

5.6

SETTING AND DISPLAYING THE SET-POINTS

1. Press the **SET key** to display the current **SET-POINT** (temperature).
2. Hold down the **SET key** and press the (**▲**) or (**▼**) keys to modify the **SET-POINT**.
3. Release the **SET key** to return to room temperature display: the new setting will be saved automatically.

Note: with the double set point configuration the display of the two set points is alternated each time SET is pressed.

5.7

DISPLAY PROBES VALUE



Press the button  **Probe values** repeatedly to toggle between probe values of the temperature detected by the sensor 1/2 room sensor / evaporator probe 1 / evaporator probe 2 / day of the current month. If the probe is faulty or not present this will show "- - -".

5.8

LEVEL 1 PROGRAMMING (USER LEVEL)

To gain access to the Level 1 configuration menu proceed as follows:

1. Press the (**▲**) and (**▼**) keys simultaneously and keep them pressed for a few seconds until the first programming variable appears on the display.
2. Release the (**▲**) and (**▼**) keys.
3. Select the variable to be modified using the (**▲**) or (**▼**) key.
4. When the variable has been selected it is possible:
 - To display the setting by pressing SET.
 - To modify the setting by pressing the SET key and the (**▲**) or (**▼**) keys.

When configuration values have been set you can exit the menu by pressing the (**▲**) and (**▼**) keys simultaneously for a few seconds until the cold room temperature reappears.

5. The new settings are saved automatically when you exit the configuration menu.

LIST OF LEVEL 1 VARIABLES (User level)

5.9

VARIABLE	MEANING	VALUES	DEFAULT
<i>r0</i>	Temperature differential referred to main SETPOINT (both set points where double)	0,2 ÷ 10,0 °C	2,0°C
<i>d0</i>	Defrost interval (hours). In the case of the double evaporator defrost start is simultaneous.	0 ÷ 24 hours 0 = disabled	4 hours
<i>d21</i>	End-of-defrost set point, evaporator 1. Defrost is not executed if the temperature read by the defrost sensor is greater than value <i>d21</i> . (If the sensor is faulty defrosting is time-based)	-35,0 ÷ 45,0 °C	15,0°C
<i>d22</i>	End-of-defrost set point, evaporator 2. Defrost is not executed if the temperature read by the defrost sensor is greater than value <i>d22</i> . (If the sensor is faulty defrosting is time-based)	-35,0 ÷ 45,0 °C	15,0°C
<i>d31</i>	Maximum defrost duration, evaporator 1 (minutes)	1 ÷ 120 min	25 min
<i>d32</i>	Maximum defrost duration, evaporator 2 (minutes)	1 ÷ 120 min	25 min
<i>d7</i>	Drip duration (minutes) At the end of defrosting the compressor and the fans remain at standstill for time setting <i>d7</i> : the defrost LED on the front of the panel flashes.	0 ÷ 120 min	0 min
<i>F5</i>	Fan pause after defrost (minutes) Allows fans to be kept at standstill for a time <i>F5</i> after dripping. This time is counted from the end of dripping. If dripping is not set the fan pause is executed directly after the end of defrosting. During the pause the fan icon flashes.	0 ÷ 10 min	0 min
<i>dEL</i>	Second system start delay (valid if nrC=2 e Set=1)	0-60 min	30 min
<i>A1</i>	Minimum temperature alarm Allows user to define a minimum cold room storage temperature. Below the value <i>A1</i> (after Ald delay) a warning is given: the alarm LED and the alarm code EL flash and the fault is also highlighted by an internal buzzer.	-45 ÷ (A2-1)°C	-45°C
<i>A2</i>	Maximum temperature alarm Allows user to define a maximum cold room storage temperature. Above the value <i>A2</i> (after Ald delay) a warning is given: the alarm LED and the alarm code EH flash and the fault is also highlighted by an internal buzzer.	(A1+1) ÷ 99°C	+45°C
<i>dF1</i>	Real-time defrost enable, evaporator 1 With <i>dF1</i> =1 it is possible to set up to 6 defrosts in real time in a day by using the parameters <i>d41</i> ... <i>d46</i> (not considered if <i>d0</i> differs from 0).	0 disabled 1 enabled	0
<i>dF2</i>	Real-time defrost enable, evaporator 2 With <i>dF2</i> =1 it is possible to set up to 6 defrosts in real time in a day by using the parameters <i>d51</i> ... <i>d56</i> (not considered if <i>d0</i> differs from 0).	0 disabled 1 enabled	0

d41...d46	Programming defrost times, evaporator 1 It is possible to set up to 6 defrosting times	00:00:00 ÷ 23:59:00	00:00:00
d51...d56	Programming defrost times, evaporator 2 It is possible to set up to 6 defrosting times	00:00:00 ÷ 23:59:00	00:00:00

5.10**LEVEL 2 PROGRAMMING (Installer level)**

To access the second programming level press the UP (▲) and DOWN (▼) keys and the LIGHT key simultaneously for a few seconds.

When the first programming variable appears the system automatically goes to stand-by.

1. Select the variable to be modified by pressing the UP (▲) and DOWN (▼) keys. When the parameter has been selected it is possible to:
 2. View the setting by pressing the SET key.
 3. Modify the setting by holding the SET key down and pressing the (▲) or (▼) key.
 4. When configuration settings have been completed you can exit the menu by pressing the (▲) and (▼) keys simultaneously and keeping them pressed until the room temperature value reappears.
5. Changes are saved automatically when you exit the configuration menu.
6. Press the STAND-BY key to enable electronic control.

LIST OF LEVEL 2 VARIABLES (Installer level)

5.11

VARIABLE	MEANING	VALUES	DEFAULT
<i>nrC</i>	Number of compressors (or solenoids or systems)	1 = 1 system 2 = 2 system	2
<i>nrE</i>	Number of evaporators	1 = 1 evaporator 2 = 2 evaporators	2
<i>Set</i>	Single or double set-point setting (ignored if nrC = 1)	1 = one setting only 2 = double setting	1
<i>rot</i>	Compressor rotation (ignored if nrC = 1)	0 = compressor rotation 1 = fixed call	0
<i>F3</i>	Fan status with compressor off	0 = Fans running continuously 1 = Fans running only if compressor is working 2 = fans disabled	1
<i>F4</i>	Fan pause during defrost	0 = Fans running during defrost 1 = Fans not working during defrost	1
<i>F6</i>	Evaporator fans activation for air recirculation. The fans activate for a time defined by F7 if they have not started working for the F6 time. If activation time coincides with the defrosting time, end of defrosting is awaited.	0 – 240 min 0 = (function not activated)	0 min
<i>F7</i>	Evaporator fans duration for air recirculation. Fans working time for F6	0-30 min	10 min
<i>dE1</i>	Evaporator 1 sensor presence Disabling the evaporator sensor causes defrosts to occur cyclically with period d0 or by real time clock and terminate according to time d31	0 = evaporator 1 sensor present 1 = evaporator 1 sensor absent	0
<i>dE2</i>	Evaporator 2 sensor presence Disabling the evaporator sensor causes defrosts to occur cyclically with period d0 or by real time clock and terminate according to time d32	0 = evaporator 2 sensor present 1 = evaporator 2 sensor absent	0
<i>d1</i>	Defrost type , cycle inversion (hot gas) or elements With 2 compressors and only 1 evaporator both compressors are activated.	0 = heater 1 = hot gas 2 = hot gas with basin 3 = heater, with temperature control	0
<i>d8</i>	Post-defrost compressor start mode. Determines whether system compressor start is possible or not if second is defrosting	0 = if an evaporator is still defrosting the second system can continue working 1 = compressors do not start until all defrosts have been completed	0
<i>Ad</i>	Network address for connection to TeleNET / Modbus supervision system.	0 ÷ 31 if SEr=0 1 ÷ 247 if SEr=1	1
<i>SEr</i>	RS-485 communication protocol	0 = TeleNet Protocol 1 = Modbus-RTU Protocol	0
<i>Bdr</i>	Modbus baudrate	0 = 300 baud 1 = 600 baud 2 = 1200 baud 3 = 2400 baud 4 = 4800 baud 5 = 9600 baud 6 = 14400 baud 7 = 19200 baud 8 = 38400 baud	5
<i>Prt</i>	Modbus parity check	0 = none 1 = even parity 2 = odd parity	0
<i>Ald</i>	Minimum and maximum temperature signalling and alarm display delay.	0÷ 240 min	120 min
<i>C1</i>	Minimum time between shutdown and subsequent switching on of the compressor.	0 ÷ 15 min	0 min

VARIABLE	MEANING	VALUES	DEFAULT
CE1	Duration of compressor ON time in the case of faulty ambient probe (emergency mode). If CE1=0 the emergency mode in the presence of error E1/E2 remains disabled, the compressor remains off and defrosting is prevented in order to conserve the remaining cold.	0 ÷ 240 minutes (0=disabled)	0
CE2	Duration of compressor OFF time in the case of faulty ambient probe (emergency mode).	5 ÷ 240 min	5 min
Hr1	Compressor 1 hour counter (can be reset by pressing the set and clock keys for 10 sec)	0 ÷ 999 tens of hours	0
Hr2	Compressor 2 hour counter (can be reset by pressing the set and clock keys for 10 sec)	0 ÷ 999 tens of hours	0
CL1	Room sensor 1 value correction	-10,0 ÷ 10,0 °C	0,0
CL2	Room sensor 2 value correction	-10,0 ÷ 10,0 °C	0,0
HSE	Maximum value attributable to set point	(LSE+1) ÷ 99°C	45°C
LSE	Minimum value attributable to set point	-45°C ÷ (HSE-1)	-45°C
bEE	Buzzer state	0 = disabled 1 = enabled	1
doC	Compressor safety time for door switch: when the door is opened the evaporator fans shut down and the compressor will continue working for time doC , after which it will shut down.	0 ÷ 5 min	0 min
Tdo	Time to re-insert compressor after opening door When opening the door and after time tdo the normal operation of the control is restored giving the alarm for open door (Ed).	0 ÷ 240 min (0 = disabled)	0 min
In1 ... In4	DI1...DI4 digital input configuration 9 = fan 2 protection (N.O.) 8 = fan 1 protection (N.O.) 7 = Stop defrosting remotely (N.O.) (reads leading edge of impulse) 6 = Remote defrost start (N.O.) (reads leading edge of impulse) 5 = Remote Stand-by (N.O.) 4 = Door switch (N.O.) 3 = Man in room alarm (N.O.) 2 = Compressor 2 protection (N.O.) 1 = Compressor 1 protection (N.O.) 0 = Disabled -1 = Compressor 1 protection (N.C.) -2 = Compressor 2 protection (N.C.) -3 = man in room alarm (N.C.) -4 = Door switch (N.C.) -5 = Remote Stand-by (N.C.) -6 = Remote defrost start (N.C.) (reads leading edge of impulse) -7 = Stop defrosting remotely (N.C.) (reads leading edge of impulse) -8 = fan 1 protection (N.C.) -9 = fan 2 protection (N.C.)	-9 ÷ 9 (the input terminals of DI1, DI2, DI3, DI4 are displayed in Appendix par. A.2) <i>N.B. in the case of digital input configured for "protection fan", the control maintains the operation and the failure is signaled on the display and via the alarm relay.</i>	In1 = 1 In2 = 2 In3 = 3 In4 = 4

VARIABLE	MEANING	VALUES	DEFAULT
Fst	FAN shutdown TEMPERATURE The fans will stop if the temperature value read by the evaporator sensor is higher than this value.	-45 ÷ 99°C	+99°C
Fd	Fst differential	1 ÷ 10 °C	2 °C
rA	DO digital output setting (the output terminal of DO is displayed in Appendix par. A.2)	2 = door resistance deicing (NO) 1 = General alarm (NO) 0 = disabled -1 = General alarm (NC) -2 = Door resistance deicing (NC)	1
StA	Setpoint deicing resistance relay If the temperature measured by the room principal probe is less than this value, it activates the auxiliary relay (if rA=± 2)	-45°C ÷ 99°C	0
dEF	Reserved parameter	---	---
dY	Day set up	01 ÷ 31	01
Mo	Month set up	01 ÷ 12	01
Yr	Year set up	00 ÷ 99	13
hMS	Time set up	Hours – minutes - seconds	12:00:00
P1	Password: protection type (active when PA is different from 0)	0 = Displays only the set point and allows alarm stop (blocks access to programming levels) 1 = displays the set point, allows alarm stop, defrost, light (blocks access to programming levels) 2 = blocks access to levels 1 and 2 during programming (all other functions permitted) 3 = blocks access to level 2 during programming (all other functions permitted)	1
PA	Password (see P1 for protection type)	0 ÷ 999 (0=disabled)	0
mOd	Mode of operation	1 = only ambient 1 regulation probe 2 = only ambient 2 regulation probe 3 = ambient 1 regulation probe, ambient 2 safety probe 4 = adjustment with the average value of the probes	1
rEL	Release software	Read only	---

5.12

SWITCHING ON THE VISION 2PLT ELECTRONIC CONTROLLER

After wiring the controller correctly, power up at 230VAC; the panel will immediately emit a beep and all segments and LEDs come on simultaneously for a few seconds.

5.13

COMPRESSOR ACTIVATION/DEACTIVATION CONDITIONS

The **VISION 2PLT** controller activates the compressor when cold room temperature exceeds setting+differential (r0); it deactivates the compressor when cold room temperature is lower than the setting.

5.14

CONFIGURATIONS

- Control of 2 motor condenser units with 2 evaporators.
- Control of 1 motor condenser unit with 2 evaporators.
- Control of unit panel with 2 evaporators.
- Control of 2 motor condenser units with 1 evaporator.
- Control of 1 motor condenser units with 1 evaporator

Functional combinations are managed by nrC (number of compressors) and nrE (number of evaporators) parameters.

5.15

SINGLE SET POINT WITH DOUBLE SYSTEM

With a single set point (parameter SEt=1, Considered set: Set 1) and double system (parameter nrC=2) the controller initially 'calls' the compressor which has worked less if rot=0 or calls compressor 1 and then 2 after the delay if rot=1. If the set point is not reached within time DeL (1st level parameter) the second presser is switched on to help. In event of Stand-by or power off compressors restart according to DeL parameter.

5.16

DOUBLE SET POINT



With SEt=1 (double set), there are 2 distinct set points for the 2 compressors. Setting of the 2 set points is done by pressing the set key: press once and the set value will appear with St1 alongside; the second time it is pressed the second set value appears with St2 alongside.

If rot=0 there will be compressor rotation (with reference to the lowest set point the compressor that has worked the least will be started). If SEt=2 DeL parameter is ignored, compressors are related to the setpoint: if the ambient temperature exceeds lowest setpoint +r0 first compressor starts (and relative fans, if enabled), if the temperature exceeds greater setpoint + r0 second compressor starts. In event of Stand-by or power off compressors restart simultaneously (1 sec delay).

DEFROST MANAGEMENT

5.17

The defrost start mode are as follows:

- *manual defrosting*: pressing the dedicated key (see section 5.2) you will enter the defrost start / stop management menu. In particular, pressing  or  it is possible to choose the defrost of plant 1 (written "1"), plant 2 (written "2") or both (written "1-2").

Pressing button  **Set** you can start / stop defrost for the selected plant. Manual defrost is possible even if you have set defrosts in real time clock.

- *according to the programmed start times* $d41 \div d46$ e $d51 \div d56$, active in the case in which the parameter of cyclic defrosting $d0$ is 0 and $dF1=1$ or $dF2=1$.

- *start-up cycle depending on the parameter* $d0$.

The start of a evaporator defrost involves the activation of the corresponding resistors relay. The parameter $d0$ acts on both evaporators and has precedence over the real time programmed defrost. Defrosting is not activated if the appropriate conditions are not present (end-of defrosting temperature ($d21$ for evaporator 1 or $d22$ for evaporator 2) set lower than the temperature read by the evaporator probe). Defrosting terminates when the end-of defrosting temperature ($d21$ or $d22$) is reached or for a maximum defrosting time ($d31$ for evaporator 1 or $d32$ for evaporator 2, also when defrost probe faulty or absent) or by manually forced end-of-defrosting (end-of-defrosting key).

The enabling of the second system in the case when the first is in defrost depends on the parameter $d8$. If $nrE=1$ the only one evaporator considered is the one of the plant 1 (evaporator 1 and fans 1).

HEATER DEFROST, WITH TEMPERATURE CONTROL

5.18

Set the parameter $d1=3$ for the management of heater defrost, end by time with temperature control. During the entire defrosting process the defrost relays are activated if the temperature read by defrost probe is lower than $d21$ or $d22$. Defrosting phase lasts $d31$ or $d32$ anyway, in spite of relays state. This allow a better defrost process and energy saving.

5.19

HOT GAS DEFROSTING

Set parameter d1=1 or d1=2 to manage defrost in cycle inversion mode.

During the entire defrosting process the compressor and defrost relays are activated. During dripping (d7) the compressor stops and, if d1=2, the defrost relays remain activated in order to ensure the ignition of the resistances of the basins. If d1=2 it may be necessary to add external electromechanical components for proper control of the solenoid valves. For a correct control of the system, the installer must use the defrost output which must allow the opening of the inversion cycle electrovalve and closing of the liquid electrovalve. For capillary systems (without thermostatic valve) it is sufficient to control the inversion cycle electrovalve using the defrost relay command.

5.20

OPERATING MODE

The control can operate in four different modes, depending on the value of the mOd parameter:

mOd = 1. Probe 1 used as regulation probe. The presence of ambient probe 2 is ignored.

If probe 1 fails alarm E1 is signaled and the control enters emergency mode (CE1 and CE2 parameters);

mOd = 2. Probe 2 used as regulation probe. The presence of ambient probe 1 is ignored.

If probe 2 fails alarm E2 is signaled and the control enters emergency mode (CE1 and CE2 parameters);

mOd = 3. Probe 1 used as regulation probe, probe 2 used as control probe.

If probe 1 fails alarm E1 is signaled and the ambient probe 2 becomes the regulation probe. If probe 2 fails alarm E2 is signaled and ambient probe 1 remains the regulation probe.

If both ambient probes fail E1 error is reported and the control enters emergency mode (CE1 and CE2 parameters).

If the temperature difference between the ambient probes is greater than 5°C for a time greater than 10 minutes then EdP alarm is signaled.

mOd = 4. Temperature control by considering the average of the values measured by the 1 and 2 ambient probes. If the ambient probe 1 fails, the ambient probe 2 is considered as the control probe (and vice versa). If both ambient probes fail E1 error is reported and the control enters emergency mode (CE1 and CE2 parameters).

CHAPTER 6: OPTIONS

TELENET MONITORING/SUPERVISION SYSTEM

6.1

In order to connect the board to the **TeleNET** network, follow the diagram below. Configure the instrument with reference to the **TeleNET** manual.

IMPORTANT: During configuration of the “Module”, select "PLUS 200 2 PLT / VISION 100 2PLT Instrument".

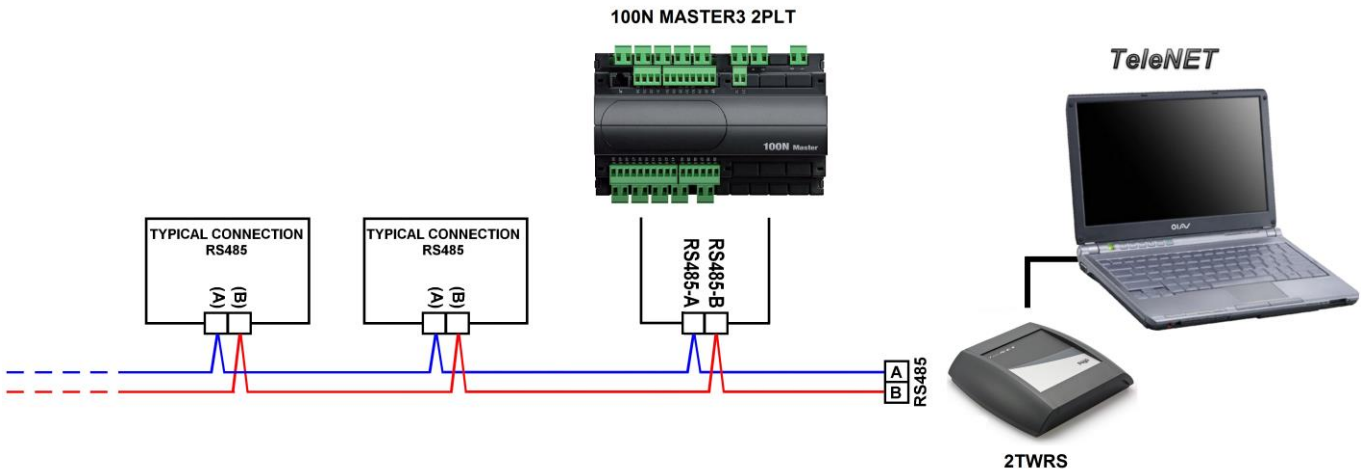

CHAPTER 7: DIAGNOSTICS

7.1

DIAGNOSTICS

In case of anomalies, the VISION 2PLT controller warns the operator using alarm codes shown by the display and an acoustic signal emitted by a buzzer inside the Operational console. If the alarm EL or EH falls without operator intervention the control keeps track of the error over time.

Long press the "mute alarm" key will display the error code already ceased. If happen in sequence an EH alarm and an EL alarm (in any order), only the alarm EH (maximum temperature alarm) is kept in memory.

ALARM CODE	POSSIBLE CAUSE / DESCRIPTION	ACTION TO BE TAKEN
E1	<i>Room temperature sensor 1 faulty</i>	<ul style="list-style-type: none"> • Check that the room sensor is working properly. • If the problem persists replace the sensor.
E2	<i>Room temperature sensor 2 faulty</i>	<ul style="list-style-type: none"> • Check that the room sensor is working properly. • If the problem persists replace the sensor.
Ed1	<i>Defrost sensor 1 faulty</i> (In this event any defrosts will have duration time d31)	<ul style="list-style-type: none"> • Check that the defrost sensor is working properly. • If the problem persists replace the sensor.
Ed2	<i>Defrost sensor 2 faulty</i> (In this event any defrosts will have duration time d32)	<ul style="list-style-type: none"> • Check that the defrost sensor is working properly. • If the problem persists replace the sensor.
E0	<i>EEPROM alarm</i> EEPROM memory error detected. (All outputs deactivated except alarms)	<ul style="list-style-type: none"> • Switch off unit and switch back on.
EL	<i>Minimum temperature alarm</i> The ambient temperature is lower than that set for the minimum temperature alarm (see A1 parameter)	<ul style="list-style-type: none"> • Check compressor status. • The probe does not correctly detect the temperature or the command to start / stop the compressor does not work.
EH	<i>Maximum temperature alarm</i> The ambient temperature is greater than that set for the maximum temperature alarm (see A2 parameter)	<ul style="list-style-type: none"> • Check compressor status. • The probe does not correctly detect the temperature or the command to start / stop the compressor does not work.
En	<i>Communication error (with power board)</i>	<ul style="list-style-type: none"> • Switch off unit and switch back on. • If problem persists contact technical assistance service.
E6	<i>Flat battery alarm</i> ; the controller will function for at least another 20 days; subsequently any power loss to the board will involve loss of time settings.	<ul style="list-style-type: none"> • Change the battery.
E0n	<i>Power Board EEPROM alarm</i>	<ul style="list-style-type: none"> • Switch off unit and switch back on.

E8	<i>Man in room alarm</i> The man in room alarm switch in the room has been pressed to indicate a dangerous situation.	<ul style="list-style-type: none"> • Reset the alarm switch inside the cold room.
Ed	<i>Door open alarm.</i> When the door switch opens and the Tdo time has elapsed, normal function of the control is reset, triggering the door open alarm (Ed).	<ul style="list-style-type: none"> • Close the door.
Ec1	<i>Compressor 1 safety device tripped</i> (e.g. Overheat or max. pressure switch).	<ul style="list-style-type: none"> • Check the compressor status. • Check compressor absorption. • If problem persists contact technical assistance service.
Ec2	<i>Compressor 2 safety device tripped</i> (e.g. Overheat or max. pressure switch).	<ul style="list-style-type: none"> • Check the compressor status. • Check compressor absorption. • If problem persists contact technical assistance service.
EdP	<i>Possible functional abnormality of one of the two probes</i> If the mOd parameter is set to 3, if the detected temperature by the main probe differs from the value measured by the control sensor for more than 5°C then the possible fault is reported (the operating system remains unchanged).	<ul style="list-style-type: none"> • Check that the room sensors are working properly.
Ev1	<i>Fans 1 protection</i>	<ul style="list-style-type: none"> • Check fan status. • If problem persists contact technical assistance service.
Ev2	<i>Fans 2 protection</i>	<ul style="list-style-type: none"> • Check fan status. • If problem persists contact technical assistance service.

ATTACHMENTS

A.1

EU DECLARATION OF CONFORMITY

LA PRESENTE DICHIARAZIONE DI CONFORMITA' E' RILASCIATA SOTTO LA RESPONSABILITA' ESCLUSIVA DEL FABBRICANTE:

THIS DECLARATION OF CONFORMITY IS ISSUED UNDER THE EXCLUSIVE RESPONSIBILITY OF THE MANUFACTURER:



PEGO S.r.l. Via Piacentina 6/b, 45030 Occhiobello (RO) – Italy –

DENOMINAZIONE DEL PRODOTTO IN OGGETTO / DENOMINATION OF THE PRODUCT IN OBJECT

MOD.: VISION 2 PLT

IL PRODOTTO DI CUI SOPRA E' CONFORME ALLA PERTINENTE NORMATIVA DI ARMONIZZAZIONE DELL'UNIONE EUROPEA:

THE PRODUCT IS IN CONFORMITY WITH THE RELEVANT EUROPEAN HARMONIZATION LEGISLATION:

Direttiva Bassa Tensione (LVD): 2014/35/UE
Low voltage directive (LVD): 2014/35/EU

Direttiva EMC: 2014/30/CE
Electromagnetic compatibility (EMC): 2014/30/EU

LA CONFORMITA' PRESCRITTA DALLA DIRETTIVA E' GARANTITA DALL'ADEMPIMENTO A TUTTI GLI EFFETTI DELLE SEGUENTI NORME:

THE CONFORMITY REQUIRED BY THE DIRECTIVE IS GUARANTEED BY THE FULFILLMENT TO THE FOLLOWING STANDARDS:

Norme armonizzate: EN 61010-1:2010, EN 61326-1:2013
European standards: EN 61010-1:2010, EN 61326-1:2013

IL PRODOTTO E' COSTITUITO PER ESSERE INCORPORATO IN UNA MACCHINA O PER ESSERE ASSEMBLATO CON ALTRI MACCHINARI PER COSTITUIRE UNA MACCHINA CONSIDERATE DALLA DIRETTIVA: 2006/42/CE "Direttiva Macchine".

THE PRODUCT HAS BEEN MANUFACTURED TO BE INCLUDED IN A MACHINE OR TO BE ASSEMBLED TOGETHER WITH OTHER MACHINERY TO COMPLETE A MACHINE ACCORDING TO DIRECTIVE: EC/2006/42 "Machinery Directive".

Firmato per nome e per conto di:
 Signed for and on behalf of:

Pego S.r.l.
 Lisa Zampini
 Procuratore Generale

Luogo e Data del rilascio:
 Place and Date of Release:

Occhiobello (RO), 08/01/2018

100N MASTER3 CONNECTION LAYOUT

A.2

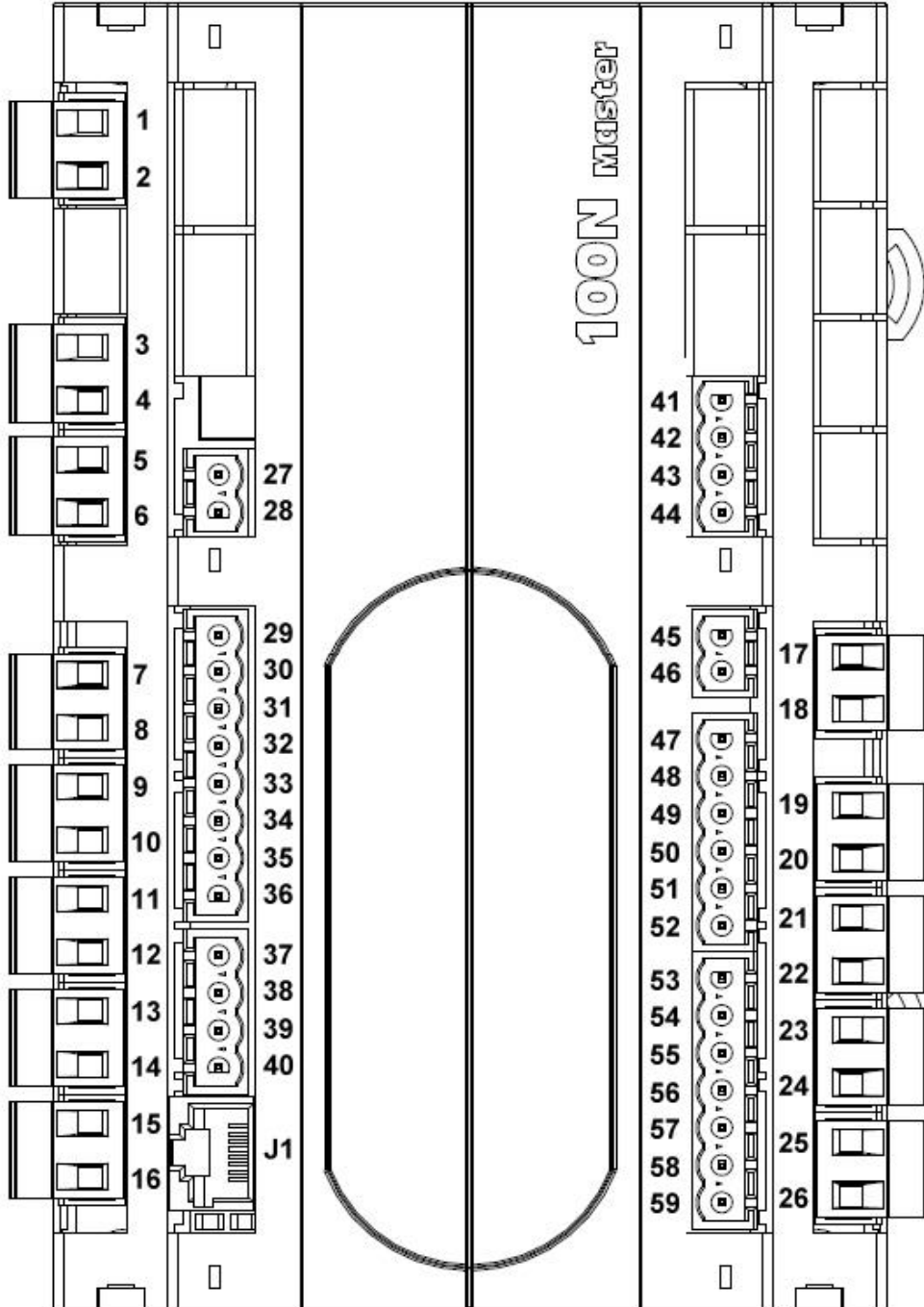

Power supply:

PIN TERMINAL	DESCRIPTION
1 – 2	<i>N – L</i> Power supply terminal 1 – 2 115÷230Vac ±10% 50/60Hz Assorbimento: 20 VA max.
45	Connect ground to terminal 45 of the console (functional earth). This connection helps to limit the effects of electromagnetic noise on the control system. The ground connection must be made in a manner consistent with applicable regulations.

Digital outputs:

PIN TERMINAL	RELAY OUTPUTS FEATURES (Voltage-free contacts)	DESCRIPTION
3 – 4	Relay 30A 240V~ (AC1) 10A 240V~ (AC3) (2HP)	Compressor 1
5 – 6	Relay 16A 240V~ (AC1) 3A 240V~ (AC3)	Compressor 2
7 – 8	Relay 16A 240V~ (AC1) 3A 240V~ (AC3)	Fans 1
9 – 10	Relay 16A 240V~ (AC1) 3A 240V~ (AC3)	Fans 2
11 – 12	Relay 16A 240V~ (AC1) 3A 240V~ (AC3)	Defrost 1
13 – 14	Relay 16A 240V~ (AC1) 3A 240V~ (AC3)	Defrost 2
15 - 16	Relay 16A 240V~ (AC1) 3A 240V~ (AC3)	Room light
17 - 18	Relay 16A 240V~ (AC1) 3A 240V~ (AC3)	DO configurable digital output (See parameter rA) (Default: rA = 1 General alarm N.O.)

Analog inputs:

PIN TERMINAL	PROBE TYPE	DESCRIPTION
29 – 30	NTC 10K	Ambient 1 probe
31 – 32	NTC 10K	Ambient 2 probe
33 – 34	NTC 10K	Evaporator 1 probe
35 – 36	NTC 10K	Evaporator 2 probe

Digital inputs:

PIN TERMINAL	DESCRIPTION	FACTORY DEFAULT SETTINGS
59 – 47	DI1 digital input	Compressor 1 Protection N.O. (In1 = 1)
59 – 48	DI2 digital input	Compressor 2 Protection N.O. (In2 = 2)
59 – 49	DI3 digital input	Man in Cold Room Alarm N.O. (In3 = 3)
59 – 50	DI4 digital input	Door Switch N.O. (In4 = 4)

TeleNET:

PIN TERMINAL	DESCRIPTION
39	Line A o terminal 3 of TWRS485
40	Line B o terminal 4 of TWRS485

Configuring internal bridges on 100N Master 3:

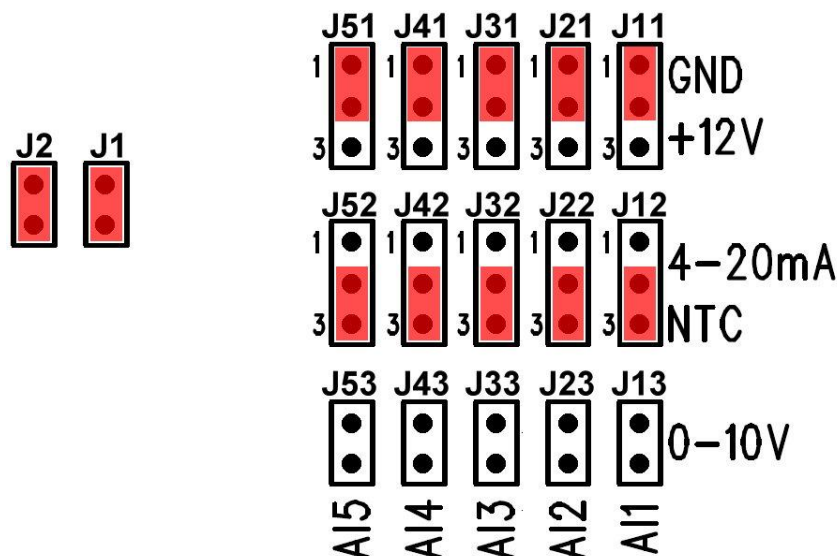



PEGO s.r.l.
Via Piacentina, 6/b 45030 Occhiobello ROVIGO – ITALY
Tel. +39 0425 762906 Fax +39 0425 762905
e.mail: info@pego.it – www.pego.it

AFTER-SALES ASSISTANCE CENTRE
Tel. +39 0425 762906 e.mail: tecnico@pego.it

Distributor: